

Shelf 812 - filtering shelf

Ref : EF 812 A
Filtering shelf to place on a work surface

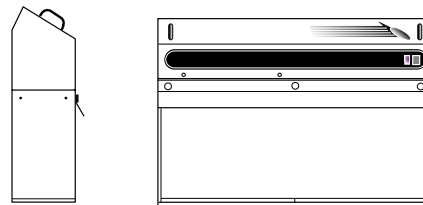

Ref : EF 812 B
Filtering shelf placed on an optional base

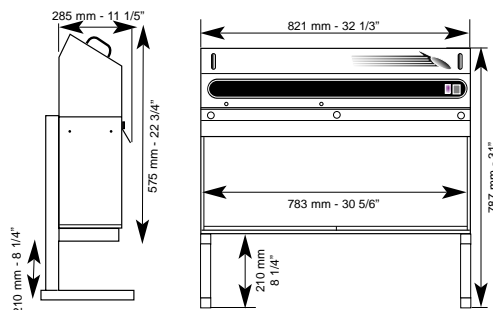
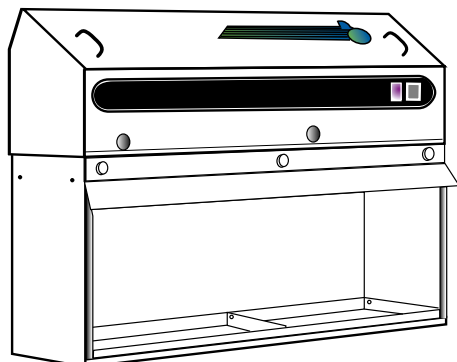

Ref : EF 812 C
Filtering shelf to be mounted to a wall

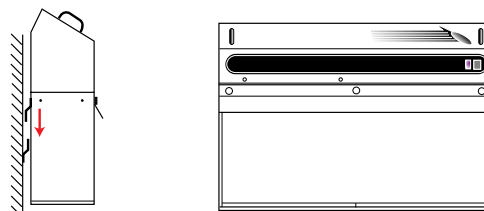

Dimensions mm - in	Width	Depth	Height
Internal	783- 30 5/6"	188 - 7 2/5"	348 - 13 5/7"
External	821 - 32 1/4"	285 - 11 1/4"	575 - 23"
			787 *- 31"

* placed on its optional base (Ref. EF 812 B)

Specifications	Shelf 812
Volume of air treated	75 m ³ /hour
Storage capacity	16 x 0.5 liters bottles or flasks
Spill tray	2x1 liter spill tray with absorbing mat
Structure	galvanized steel with epoxy-polyester anti-acid coating
Total power consumption	20 Watt
Maximum amperage absorbed	0,1 A
Tension/frequency	230/50 Volts/hertz
Blower	very silent turbine type blower
Sound level	45 dbA

Options	
Base	Ref : B
Set of 10 absorbing mats	Ref : PIDMS015