

EN

Instruction manual



Fuego^{SCS} basic RF

Safety Enhanced
Laboratory Gas
Burner with radio
operated foot pedal



DIN 30665, part 1



- 1 - Function knob
- 2, 2a - Dual knob: 2 - Gas adjustment
2a - Air adjustment
- 3 - LED Standard
- 4 - LED StartStop
- 5 - LED Button
- 6 - LED Burner head HOT / BHC
- 7 - Burner head
- 7a - Flame orifice

- 8 - Connector for foot pedal (Cable)
- 9 - Power connector for 9 V DC
- 10 - Gas inlet R 1/4" L (left hand thread)
- 11 - Holding device for inoculation loop holder

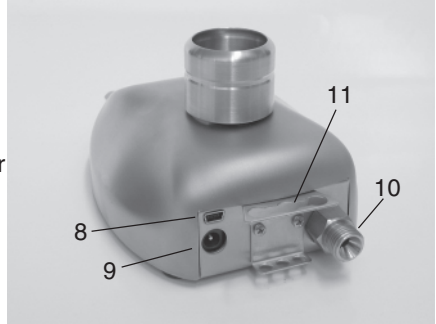

- 12 - Burner head screw
- 13 - Monitor electrode
- 14 - Ignition electrode

- 15 - Active nozzle
- 16 - Nozzle holder for alternative gas
- 17 - Cover of the burner shaft
- 18 - Retaining screw for cover of the burner shaft
- 18a- Position screw for the cover
- 19 - Guide slots for tilt adjustment

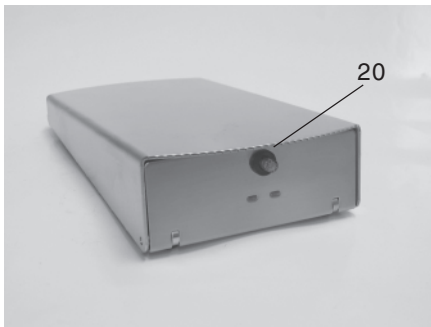
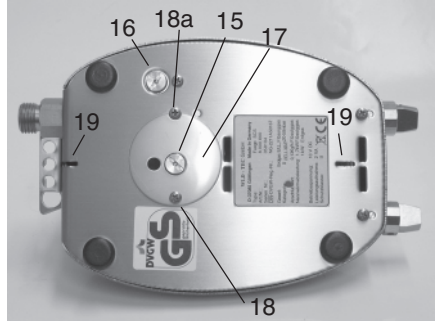

- 20 - Function LED and programming key

- 21 - Battery compartment (2 x AA, Mignon)
- 21a - Transport insulation for the batteries

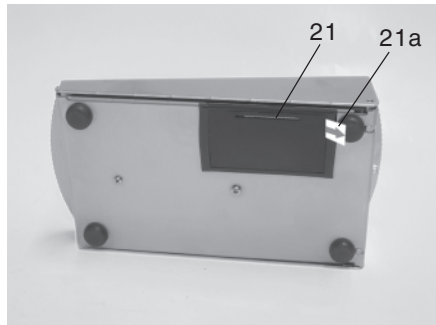

Read these instructions carefully to familiarize yourself with the product. Please retain these operating instruction for future reference.

Use: Safety laboratory gas burners for heating and flame sterilizing. Ideal for use in cleanroom workbenches and the laboratory.

**WARNING: DO NOT LEAVE THE ACTIVATED LABORATORY
GAS BURNER UNATTENDED!**

SAFETY PRECAUTIONS:

- This product is designed for exclusive use without restrictions within EU states (as well as in other states that adhere to Directive 1999/5/EC).
- On unpacking the unit, check for possible transportation damages. Do not operate the unit if damages are visible.
- After use or for any longer period of time without attendance, turn the main gas supply off and turn off the gas burner at the function knob (1).
- Pay attention to your relevant rules for using liquid gas.
- Only use DVGW safety tubings with thread or tubing connectors. Check the condition of the tube/hose frequently. Depending upon type of tube/hose, hose clamps are required.
- All gas connections must be adequately tightened with two wrenches. Ensure gas proofness with a suitable test fluid / equipment. DO NOT seal the swivel nut with Teflon tape etc.
- Keep hands or other parts of the body away from the burner orifice (7a).
- Do not operate the unit near flammable liquids or hazardous materials.
- Unattended operation of the unit is not permissible.
- Always work in a well-ventilated area.
- Note that the burner orifice (7, 7a) remains hot after the flame has been extinguished. Do not touch. Can cause burns.
- Allow sufficient time for flame orifice (7a) to cool down prior to cleaning, disinfecting, servicing or transport. Ensure that the unit and the gas supply are turned off.
- Because of the connectors at the back of the unit the backside should not be sterilized with a flame.
- Allow sufficient time for burner head (7) to cool down prior to disassembling.
- Operate the unit with assembled burner head (7) only.
- After cleaning the burner head (7) allow sufficient time to dry before assembling again.
- Keep substances away from the flame orifice (7a).
- Before mounting a nozzle check the O-Ring (20). Replace the sealing if damaged or worn.



The range: Fuego SCS basic RF

Art.-No. 8.003.000 - RF

Stainless steel radio frequency foot pedal (Art.-No. 8.000.406-RF) (battery operated)

2 Mignon-Batteries (AA)

3 standard-programs for button (function knob) and foot pedal

SCS (Safety Control System)

BHC (Burner Head Control)

Removable and decomposable burner head

Tilt mechanism, right / left (23)

Holding device for 3 inoculation loop holders

Nozzles for natural gas, propane/butane gas

Turbo flame

Wrench 17 mm (21) for gas connection

Screwdriver (22) for burner head and cover of the burner shaft

Tubing connector with swivel nut (24)

Power connection

Instruction manual and 2-year warranty



1. Setup Procedure:

The unit is shipped with the nozzle for natural gas (N) installed.

The nozzle must be changed if other gas is to be used.

Replacement procedure: Remove the Nozzle P from the nozzle holder (16) with a coin or the edge of the wrench (21) by turning it counterclockwise.

Remove the active Nozzle N for natural gas (15) in the same way and exchange the nozzles.

ATTENTION: Before mounting a nozzle check the O-Ring (20).

Replace the sealing if damaged or worn (Art.-No. 8.000.010).

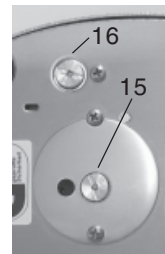

Now you are ready to connect the gas supply to the gas inlet (10).

The correct pressure for natural gas is within the range of 18 - 25 mbar, for propane/butane gas 28 - 57 mbar.

Only use DVGW or other gas approved safety tubings with thread or tubing connectors (24). Check the condition of the tube/hose frequently. Depending upon type of tube/hose, hose clamps are required.

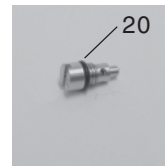

All gas connections must be adequately tightened with the wrench (21) (SW 17mm, included). Ensure gas proofness with a suitable test fluid / equipment. Do not seal up the included tubing connector (24) and swivel nut with Teflon tape etc.

A DVGW-proven or other gas approved pressure regulator (50mbar) must be used for liquid gas.

Pay attention to your relevant rules for using liquid gas.

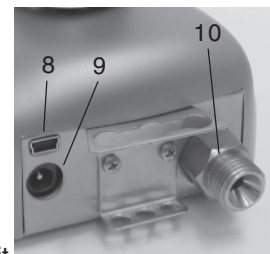

1.1 Electrical connection:

Insert the power cord into the socket (9) on the back panel of the unit, or into the socket of the hard-wired foot pedal (optional).

The default supply must be connected to a voltage source of 100 - 240 V / 50/60 Hz.

2. Operation: Flame regulation

The flame can be varied in size and intensity by turning the gas knob (2) and adjusting the air knob (2a) to suit all requirements.

Attention: When operating the unit for the first time or after changing the nozzle, turn the gas adjustment knob (2) two revolutions to the left and turn the air adjustment knob (2a) 3-4 revolutions to the left, too.

2.1 Operation: On-Off switch, operating mode

Switch the unit on by a short push on the function knob (1). It can be turned off by a long push (2 seconds +) on the function knob. By turning the function knob (1) the foot pedal operating mode "Standard" or "StartStop" or the operating mode "Button" can be chosen. The corresponding LED (3), (4) or (5) lights up. **Note: The LEDs Standard (3) and Start-Stop (4) will flash alternately until a wireless foot pedal has been detected within range (2 - 5 metres) or a hard-wired foot pedal has been connected to the foot pedal socket (8).**

2.2 Operation: Foot pedal activation and function:

Attention: Switch the burner off prior to operation to prevent inadvertent activation of the burner.

Remove the transport insulation from the batteries (21a) prior to first use. The two mignon batteries (AA) have already been inserted into the battery holder in the wireless foot pedal (21).

Once the transport insulation has been removed, switch burner on again.

The wireless foot pedal does not have a mains switch, but is automatically switched on when operated. The foot pedal also deactivates itself after a certain time once the laboratory gas burner has been switched off.

The radio system can be used without changing any further settings as the laboratory gas burner and the wireless foot pedal have already been programmed to each other (**gas burner and foot pedal programming, see paragraph 2.4**) by the manufacturers.

Attention: The laboratory gas burner is started as soon as the foot pedal is operated and the LEDs (3) and (4) stop blinking. Attention: Flame!

The corresponding LED for the foot pedal program (3) or (4) that has been selected will also light up continuously in green and signals that the wireless foot pedal is connected to the appliance. (In cases where the alternate flashing continues after operation and the foot pedal is not being detected, (see paragraph 2.4.)

The LEDs Standard (3) and Start-Stop (4) of the laboratory burner will flash alternately as soon as the wireless foot pedal is no longer within range (2 – 5 metres) or the radio signal is interrupted. The flame is switched off automatically for safety reasons if it is active at such points in time.

Note: As an alternative, the burner can also be operated using a hard-wired foot pedal (optional): In this case, plug the foot pedal cable into the foot pedal connector (8) on the back of the burner. The burner will detect the foot pedal and the alternate flashing of the LEDs Standard (3) and Start-Stop (4) will cease as soon as the foot pedal has been plugged in.

2.3 Operation: Function LED on the wireless foot pedal (20):

The function LED (20) flashes at different intervals to indicate different operational status.

No LED:	The foot pedal is deactivated / switched off.
Brief, faint flashes:	Fully functional, unimpeded radio transmission
Brief, intense flashes:	Renewed radio transmission at weak radio signal strength or signal overlap.

Brief, intense flashes at rapid set intervals:

The RF stick is out of range or has been switched off. If no burner is detected after 40 flashes, the foot pedal switches itself off.

Intermittent lighting up of the LED, duration approx. 1 sec.:

batteries low (see paragraph 8)

Slight glow:

Programming in progress (see paragraph 2.4)

2.4 Foot pedal programming:

The laboratory burner and foot pedal can be newly programmed to each other if the signal is interrupted or in cases of parallel use of several radio systems. For programming of the radio channel, place the laboratory gas burner close to the wireless foot pedal (max. 30 centimetres). Programming has a restricted range to avoid inadvertent re-programming of other burners. (In cases where undesired re-programming of a neighbouring burner occurs, switch it off during the programming procedure.)

- Programming procedure:

Attention: Adhere to the sequence for the programming procedure. Close the gas regulator (2) by turning it clockwise to avoid inadvertent activation of the flame.

1. Switch off laboratory gas burner.
2. Switch on foot pedal by operating briefly or press again briefly.
3. Switch the laboratory gas burner.
4. Shortly afterwards, press the programming key (20) on the foot pedal for approx. 1 second to start the programming procedure. The function LED (20) will now start to glow. This procedure can last for between 0.5 and 30 seconds. As soon as the laboratory burner and the foot pedal have been successfully programmed, the glowing is switched off and the function LED (20) switches to brief, faint flashes.

Note: The laboratory burner and the foot pedal have already been programmed to each other by the manufacturers.

2.5 Operation: Application programs

- **BUTTON StartStop:** The flame is ignited by operation of the function knob (1). The flame is extinguished after renewed actuation of the function knob (1).

- PEDAL Standard:

The flame is ignited by operation of the foot pedal. The foot pedal remains depressed for the duration of use. The flame is extinguished upon release of the pedal.

- PEDAL Start-Stop:

The flame is ignited by operation of the foot pedal. The flame is extinguished after renewed actuation of the foot pedal. Additionally the flame is automatically extinguished when the burning timer has expired after 60 min. Alternatively the flame can be extinguished by a short push on the function knob.

2.6 Operation: Switch-off

The unit can be turned off by pushing the function knob (1) for more than 2 seconds. The foot pedal is deactivated automatically.

3. Safety symbols and safety functions:

- **Residual heat display:** LED "Burner head HOT / BHC"  indicates a hot burner head.

Attention: If the LED "burner head HOT / BHC" lights up DO NOT TOUCH the burner head. Can cause burns! Even after switching-off the unit the residual heat LED remains on till the burner head is cooled down.

Notice: Disconnecting the power supply or removing the power cord will clear the residual heat display even if the burner head is still hot.

-- **BHC:** If the burner head is clogged the amber LED "Burner head HOT / BHC" will flash. Additionally, if "burner head HOT / BHC" is flashing, the maximum burning time in the operating mode "Button" and Pedal "StartStop" is limited to 30 seconds (see paragraph 2.5). If burning times longer than 30 seconds are required in case of a clogged burner head, the operating mode "Standard" can be used without time limit. If "Burner head HOT / BHC" is blinking it is requested to clean the burner head immediately (see paragraph 5.1).

- **Automatic unit switch off:** The unit switches itself off automatically after 4 hours if the flame has not been lit in this period. All indicated malfunctions are automatically switched off after 4 hours, too (see paragraph 4). For further operation, switch the unit on again.

4. Error displays:

- **Ignition failure: Green LED "Button", "Standard" or "StartStop" blinks 2x**

This signal appears and indicates a malfunction if the flame fails to ignite after 7 seconds. In case of ignition failure check the burner head (7) for possible clogging, check the correct input pressure of the gas supply and verify that the correct nozzle is installed.

In case of this malfunction the gas supply will be shut off automatically.

Nozzle N: natural gas, 18-25 mbar **Nozzle P:** propane-/ butane gas, 47-57 mbar

- **Flame failure: Green LED "Button", "Standard" or "StartStop" blinks 3x**

This signal indicates a malfunction if the flame is extinguished by external factors and fails to reignite within 5 sec. In case of flame failure check the burner head (7) for possible clogging and verify the correct input pressure of the gas supply.

In case of this malfunction the gas supply will be shut off automatically.

- **Overtemperature: Green LED "Button", "Standard" or "StartStop" blinks 4x**

This signal indicates a malfunction if the interior temperature has exceeded 70 °C. At a normal room temperature with normal air circulation the unit is suited for continuous operation.

In case of overtemperature increase the air ventilation or change the operation site.

In case of this malfunction the gas supply will be shut off automatically.

- **Burner head assembly monitor: Green LED "Button", "Standard" or "StartStop" blinks 5x**

This message indicates that the burner head is removed. Further operation is possible after the burner head is reinstalled.

- **BHC: Amber LED "Burner head HOT / BHC" flashes**

This signal indicates that the time limit (30 seconds) is turned on in operating mode "StartStop" and "Button" due to a clogged burner head. For cleaning the burner head see paragraph 5.1.

- **LEDs Standard (3) and Start-Stop (4) are flashing alternately**

Wireless foot pedal out of range or signal interrupted.

Alternative: Hard-wired foot pedal not connected to the burner.

Plug in foot pedal / switch on wireless foot pedal or move within range (see paragraph 2.1).

If necessary, re-programme the wireless foot pedal. (see paragraph 2.4)

Notice: All error displays can be reset by a long push (2 seconds+) on the function knob (1). (In case of overtemperature the unit needs to be cooled down and in case of burner head assembly monitor the burner head needs to be reinstalled prior a reset is possible.)

5. Cleaning and sterilizing:

Allow sufficient time for burner orifice (7, 7a) to cool down before disassembling or cleaning the burner head. Check the unit is disconnected and that the gas supply is turned off at the mains. The burner can be cleaned with customary commercial disinfectants. Additionally, it is possible to remove the burner head and to clean it separately. The stainless steel and glass construction allow 100% UV-radiation sterilization and short time surface flame sterilization. Attention: Because of the connectors at the back of the unit the backside should not be sterilized with a flame.

5.1 Burner head disassembly and cleaning:

Allow sufficient time for burner orifice (7,7a) to cool down before disassembling or cleaning the burner head. Check the unit is turned off, that the gas supply is turned off at the mains. Clean the burner head with customary commercial disinfectants, sterilize it in an autoclave or wash it in a dishwasher. To remove the burner head proceed as follows:

Unscrew the burner head screw (12) completely with the included screwdriver. Turn approx. 8 revolutions to the left.

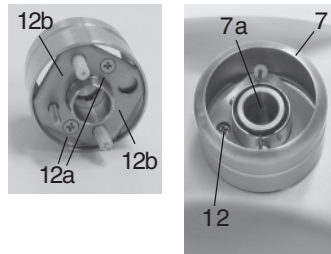

Now remove the burner head from the device by pulling it upwards.

Reinstallation is performed in the reverse sequence.

The dismantled burner head can be even dismantled into the individual components for in-depth cleaning: Unscrew both screws (12a) and take off the base plate (12b) of the burner head which was fixed by the two screws (12a). After the base plate is removed both electrodes can be pulled out for separate cleaning. Reinstallation is performed in the reverse sequence.

5.2 Burner shaft cleaning:

Unscrew the screw (18) completely with the included screwdriver. Take off the cover (17) of the burner shaft. Now the burner shaft can be cleaned or solid substances which have fallen into the unit can be removed.

Reinstallation is performed in the reverse sequence. Take care that the notch of the cover fits to the screw (18a).



6. Turbo flame:

If the cover of the burner shaft (17) is removed the flame is extremely firm and consistent.

To take off the cover of the burner shaft unscrew the screw (18) completely with the included screwdriver. With an open burner shaft the intensity of the flame cannot be adjusted by the air knob (2a) any longer. During the use of the turbo flame most of the needed air is taken inside through the open burner shaft. Remounting the cover of burner shaft. (see paragraph 5.2)

7. Tilt adjustment:

Insert the tilt adjustment (23) into the slots (19) at the bottom of the unit. The tilt-adjustment can be used to the left or right side to protect the burning chamber from contamination when working with liquids.

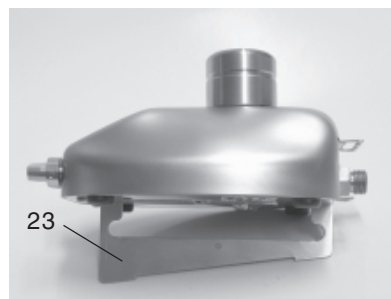

8. Changing the batteries:

Change the batteries in the wireless foot pedal as soon as the function LED **(20)** signals "batteries low". (intermittent lighting up of the LED, duration approx. 1 sec.)

Attention: Switch off the laboratory gas burner while changing the batteries, to avoid inadvertent activation of the laboratory burner through unintended pressing of the foot pedal while inserting the batteries.

Change both mignon batteries (AA) in the battery holder in the wireless foot pedal **(21)**. Pay attention to correct insertion in accordance with the batteries' polarity. (see label in the battery holder of the foot pedal)

9. Warranty:

All Fuegos are covered under our two-year manufacturer warranty against any manufacture defects in material and workmanship. The WLD-TEC warranty guarantees all Fuegos under normal usage conditions and does not cover any damages as a direct result of user misuse or/and abuse. The warranty is void upon any unauthorized servicing, disassembly or modifications.

Notes

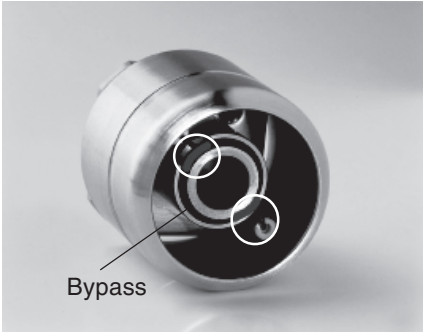
Troubleshooting guide	
The green LED “Standard“ or “StartStop“ does not light up Check for correct connection and specification of the power adapter. Ensure that the original power adapter is used. Specifications: 9 V / DC, 1A Polarity: + —  -	
The foot pedal does not work Check for correct connection of the foot pedal. Ensure that the foot pedal socket and plug is not twisted or broken.	
No Flame In case of ignition or flame failure check if the burner head is clogged. Verify the input pressure of the used gas. Ensure that the correct nozzle is installed in the unit. Nozzle N : natural gas, input pressure: 18-25 mbar Nozzle P : propane / butane gas, input pressure: 47-57 mbar	
	LED “Burner head HOT / BHC“ flashes / Inspection of the burner head (clogging) Take care that there are no liquids or other substances at the Bypass (area between the inner and the outer ring) Especially remove substances in the marked areas at the electrodes. If there are contaminants in this area, the flame cannot encircle the electrodes correctly. Clean this areas with a brush. The burner head can be cleaned with customary commercial disinfectants, or it can be sterilized in an autoclave or washed in a dishwasher.
In operating mode “Button“ or Pedal “StartStop“ flame burns 30 seconds, only BHC time limit is active, LED “Burner head hot / BHC“ is blinking. The burner head is clogged and must be cleaned (see paragraph 3 and 5.1).	
Flame too small / large / soft Check the position of the air and gas adjustment. Check if the correct nozzle is installed. Nozzle N : natural gas, 18-25 mbar Nozzle P : propane / butane gas, 47-57 mbar Check if the drilling of the active nozzle is blocked. Unscrew the active nozzle. (see paragraph 1) If the drilling is blocked clean with a brush or compressed air.	
No ignition spark/LED “Burner head HOT/BHC“ flashes but the burner head is clean Check if the ceramic electrodes are in good condition. In some cases the electrodes may break. To check move the ends of the electrodes. If they are not moving they should be okay. If they are moving more than 0.5 mm the electrodes are broken. The electrodes can be dismantled and changed by the user. (see paragraph 5.1)	

<p>The burner shuts-off due to overtemperature frequently In case of overtemperature increase the air ventilation or change the operation site.</p>
<p>Green LED "Button", "Standard" or „StartStop“ blinks 2x Ignition failure (see paragraph 4)</p>
<p>Green LED "Button", "Standard" or „StartStop“ blinks 3x Flame failure (see paragraph 4)</p>
<p>Green LED "Button", "Standard" or „StartStop“ blinks 4x Overtemperature (see paragraph 4)</p>
<p>Green LED "Button", "Standard" or „StartStop“ blinks 5x This message indicates that the burner head is removed or not mounted correctly. Reinstall burner head and reset the unit by a long push on the function knob (1) (see paragraph 4).</p>
<p>Amber LED "Burner head HOT / BHC" is on permanently Residual heat display is active. Attention: DO NOT TOUCH the burner head (see paragraph 3).</p>
<p>LEDs Standard (3) and Start-Stop (4) are blinking alternately Wireless foot pedal out of range or signal interrupted (see paragraph 2.1) In cases of frequent occurrence of this error, check the function LED on the wireless foot pedal (20) and programme a new channel or replace weak batteries, as appropriate. (see paragraph 2.4 or 2.3 & 8)</p>
<p>Service address:</p> <p>WLD-TEC GmbH Production & Service Halle-Kasseler-Str.49 37318 Arenshausen Germany</p> <p>Telefon: +49 36081 68940 Telefax: +49 36081 68942 Email: sales@wld-tec.com Internet: www.wld-tec.com</p>

Technical data:

Technology Microprocessor

Programs

Foot pedal: Standard (flame during pressed foot pedal)
Start-Stop with timer, 60 min

Button: Start-Stop with timer, 60 min

Safety features

Safety Control System (SCS):
(with gas safety cut off) ignition and flame control, temperature monitor
burner head clogging and assembly monitor (BHC)
automatic unit switch off, 4h
residual heat display

**Gas supply and consumption**

Gas supply: 1/4" left + filter

Gas types: ll2ELL3B/P: natural gas E/LL, 18 - 25 mbar
liquid gas, 20 - 50 mbar

Connected load: 70 g/h liquid gas

Continuous cartridge operation: CV 360 - 40 min, Express 444 - 50 min,
CG 1750 - 150 min, C 206 - 170 min,
CP 250 - 210 min, CV 470 - 370min

Temperatures

Flame temperature: 1350 °C on liquid gas
1300 °C on natural gas (E)

Temperature threshold level: 1 kW liquid gas, 1 kW natural gas

Electrical

Power consumption: 2 VA

Power connection: 100 - 240 V / 50/60 Hz / max. 0.3 A
9 V DC / 1 A

Power supply foot pedal: 2 x AA (Mignon)

Mechanical

Casing and operating controls: stainless steel / glass, UV and solvent resistant

Burner head: removable and decomposable, stainless steel

Cover of the burner shaft: Ø 23 mm, with drains

Measurements (B x H x T): 103 x 49 x 130 mm

Weight: 700 g

Radio Frequency System

Range: 2 - 5 m

Frequency: 2400- 2483,5 MHz

Output power: < 10mW

Batteries foot pedal: 2 x AA (Mignon)

Life time batteries (foot pedal): approx. 2000 hours
(for 8 hours of operation per day: > 1 year)

Channels: 253

Licences

DIN-DVGW Reg.-Nr.: NG-2211AS0167

CE: EN 61326-1, EN 61010-1
EN 301489 -1 -3, EN300440 -1 -2

EEC guidelines: 2004/108/EC, 73/23/EEC, 1999/5/EEC (R&TTE)



WLD - TEC GmbH

Sales:

Spandauer Weg 1
D - 37085 Göttingen
Telefon: +49 (0)551/793789
Fax: +49 (0)551/793707

Internet: <http://www.wld-tec.com>

Production und Service:

Halle-Kasseler Straße 49
D - 37318 Arenshausen
Telefon: +49 (0)36081/68940
Fax: +49 (0)36081/68942

Email: sales@wld-tec.com