



47001-88

MODEL 2100AN
LABORATORY TURBIDIMETER
INSTRUMENT MANUAL

For Use With Software Version 1

TABLE OF CONTENTS

SAFETY PRECAUTIONS	7
SPECIFICATIONS.....	9
OPERATION	13
SECTION 1 GENERAL DESCRIPTION	15
1.1 Instrument Description.....	15
1.2 Standard Accessories.....	15
1.3 Principle of Operation	15
1.4 Preparation for Use.....	16
1.4.1 Unpacking.....	16
1.4.2 Operating Environment.....	17
1.4.3 Operating Power Selection	17
SECTION 2 TURBIDITY MEASUREMENT	19
2.1 Operating Controls and Indicators	19
2.2 Measuring Turbidity.....	19
2.2.1 Nephelometric Measurement Procedure.....	20
2.2.2 Measurement Hints.....	21
2.3 Measurement Techniques.....	22
2.3.1 Cleaning Sample Cells.....	22
2.3.2 Applying Silicone Oil	22
2.3.3 Preparing Dilution Water	23
2.3.4 Indexing and Matching Sample Cells.....	24
2.3.5 Removing Air Bubbles (Degassing).....	27
2.3.6 Signal Averaging.....	29
2.3.7 Measuring Over-Range Samples	30
2.3.8 Condensation (Fogging)	33
2.3.9 Calibration Check	33
2.3.10 Representative Sampling	33
SECTION 3 OPERATION	35
3.1 Operational Controls and Indicators	35
3.1.1 Using the RANGE Key.....	37
3.1.2 Using the UNITS/EXIT Key	37
3.1.3 Using the SIGNAL AVG Key	38
3.1.4 Using the FLOW Key	38
3.1.5 Using the LINE FEED Key	38
3.1.6 Using the RATIO key	38
3.1.7 Using the PRINT Key.....	39
3.1.8 Using the CAL/ZERO Key.....	39
3.1.9 Using the ENTER Key	39
3.1.10 Using the Arrow Keys	39
3.1.11 Using the SAMPLE Key.....	40
3.1.12 Using the SETUP Key	40
3.1.13 Key Annunciator Tone (Beeper).....	40
3.2 Calibration.....	40

TABLE OF CONTENTS, continued

3.2.1 Formazin Stock Solution	41
3.2.2 Dilution Water	41
3.2.3 Preparing Recommended Formazin Dilutions	41
3.2.4 Calibrating the 2100AN (using Formazin Standards).....	43
3.2.5 Handling StablCal® Sealed Vial Standards.....	46
3.2.6 Calibrating the Turbidimeter (Using StablCal® Sealed Vial Standards).....	47
3.2.7 Formulating Formazin Stock Solution	49
3.3 Special Research Applications.....	50
3.3.1 Ignoring Dilution Water	50
3.3.2 Editing Calibration Data Points.....	50
3.3.3 Preparing Formazin Dilutions - User Selected.....	51
3.3.4 Calibrating the 2100AN (user selected standards).....	51
SECTION 4 AIR PURGE SYSTEM.....	53
4.1 Air Purge Connection	53
SECTION 5 USING FLOW-CELL SYSTEM APPARATUS	55
5.1 Description.....	55
5.2 Flow-Cell Kits (Low Pressure)	56
5.2.1 Manual Flow-Cell Kit (Low Pressure).....	57
5.2.2 Automated Flow-Cell Kit (Low Pressure)	60
5.2.3 Tips for Flow-Cell Kits (Low Pressure).....	65
5.2.4 High Pressure Flow-Cell Kit	66
5.2.5 Flow-Cell Maintenance	69
SECTION 6 DATA OUTPUT.....	71
6.1 Recorder Output.....	71
6.1.1 Setting Recorder Minimum Value.....	71
6.1.2 Setting Recorder Maximum Value	72
6.1.3 Setting Recorder Minimum Output.....	72
6.1.4 Setting Recorder Full-Scale Output	72
6.2 RS232 Connection	73
6.3 Instrument Communication	75
6.4 Printer.....	76
6.4.1 Built-In Printer	76
6.4.2 Printer Setup Commands.....	77
6.5 Using a Computer (RS232 Operating Commands)	78
SECTION 7 INSTRUMENT CLOCK.....	81
7.1 Clock Description	81
7.2 Setting Hours and Minutes	81
7.3 Setting the Month and Day	81
7.4 Setting the Year.....	81
7.5 Displaying Current Time	81

TABLE OF CONTENTS, continued

SECTION 8 CELL ADAPTERS	83
8.1 Using Cell Adapters	83
8.1.1 Installing and Removing Cell Adapters.....	83
SECTION 9 COLORIMETRIC MEASUREMENT	85
9.1 Filter Modules	85
9.1.1 Installing Filter Assemblies	85
9.1.2 Developing Applications Using Alternate Wavelengths	86
9.2 Measurements in Color, % Transmittance and Absorbance	86
9.2.1 Using Color Units (Platinum Cobalt Color Units Calibration Procedure)	86
9.2.2 Tips for Color Measurement.....	88
9.2.3 Using Transmittance Units (Transmittance 100% Procedure)	89
9.2.4 Using Absorbance Units (Absorbance Zero Procedure)	89
SECTION 10 APPLICATION SPECIFIC MEASUREMENTS	91
10.1 Application Specific Methods	91
10.2 Application Specific Calibrations	92
10.2.1 Initial ASC Entry	93
10.3 ASC Review	95
10.4 Editing an ASC Point	95
10.5 Deleting a Single ASC Point.....	96
10.6 Deleting All ASC Points	96
INSTALLATION AND MAINTENANCE	97
SECTION 11 MAINTENANCE	99
11.1 Cleaning	99
11.2 Lamp Replacement.....	99
SECTION 12 TROUBLESHOOTING	101
12.1 Introduction	101
12.2 Error Codes	101
12.3 Diagnostic and Setup Functions.....	102
12.3.1 Basic Diagnostic Codes	102
12.3.2 Other Instrument Diagnostics	104
SECTION 13 REPLACEMENT PARTS AND ACCESSORIES	105
GENERAL INFORMATION	107
How To Order.....	109
Repair Service	110
Warranty	111

SAFETY PRECAUTIONS

Please read this entire manual before unpacking, setting up, or operating this instrument. Pay particular attention to all danger and caution statements. Failure to do so could result in serious injury to the operator or damage to the equipment.

To ensure the protection provided by this equipment is not impaired, do not use or install this equipment in any manner other than that which is specified in this manual.

Use of Hazard Information

If multiple hazards exist, this manual will use the signal word (Danger, Caution, Note) corresponding to the greatest hazard.

DANGER

Indicates a potentially or imminently hazardous situation which, if not avoided, could result in death or serious injury.

CAUTION

Indicates a potentially hazardous situation that may result in minor or moderate injury.

NOTE

Information that requires special emphasis.

Precautionary Labels

Read all labels and tags attached to the instrument. Personal injury or damage to the instrument could occur if not observed.



This symbol, if noted on the instrument, references the instruction manual for operational and/or safety information.



This symbol, if noted on the instrument, references the instruction manual for operational and/or safety information.



Section 1.4.3 Operating Power Selection on page 13



Section 2.1 Measuring Turbidity on page 15



Section 4.1 Air Purge Connection on page 41



Section 5.2.4 High Pressure Flow-Cell Kit on page 53



Section 6.2 RS232 Connection on page 58



Section 11.2 Lamp Replacement on page 83

SPECIFICATIONS

(Specifications subject to change without notice)

Principle of Operation: Nephelometric

Configuration Modes (selectable):

Range Selection: Manual or Automatic

Signal Averaging: ON or OFF

Ratioing: ON or OFF

Measurement Units: Measurement Unit: NTUs, EBCs, Nephelos, A (Abs), %T, CU (color units) and ASC (2 user-defined units)

Ranges (With Ratio ON)

NTU Mode: 0-10000 NTU with automatic decimal point placement or 0-0.999,

0-9.99, 0-99.9, 0-10,000 with manual range selection

Nephelo Mode: 0-67000 with automatic decimal point placement or 0-9.99, 0-99.9 and 0-67000 with manual range selection

EBC Mode: 0-2450 with automatic decimal point placement or 0-0.999, 0-9.99, 0-99.9 and 0-2450 with manual range selection

Ranges (With Ratio OFF)

NTU Mode: 0-40

Nephelo Mode: 0-268

EBC Mode: 0-9.8

Accuracy: $\pm 2\%$ of reading plus 0.01 NTU from 0-1000 NTU; $\pm 5\%$ of reading from 1000 to 4,000 NTU; $\pm 10\%$ of reading from 4000 to 10,000 NTU based on Formazin primary standards and with Ratio Mode ON, $\pm 2\%$ of reading plus 0.01 NTU from 0-40 NTU with Ratio OFF.*†£

Color Measurement Accuracy: (1 CU = 1 Color Unit): ± 2 CU from 0-30 (calibrated at 15 CU); ± 5 CU from 0-500 CU (calibrated at 500 CU)*‡

Abs (Photometric Linearity): $\pm 0.005A$ from 0-1A at 455 nm*†

%T (Photometric Linearity): ± 0.12 %T from 10 to 100%T at 455 nm*†

Resolution: 0.001 NTU/EBC/A; 0.01 Nephelo; 0.1 %T; 1 CU.

Repeatability: $\pm 1\%$ of reading or ± 0.01 NTU, which ever is greater*

Response Time: 6.8 seconds with signal averaging off or 14 seconds with signal averaging on (based on default setting of 10)

Standardization: Formazin Primary Standards (NTU); Platinum Cobalt (Pt-Co) Color Standard Solution (CU)

* Reference conditions: 23 \pm 2 °C, 50% \pm 10% RH noncondensing, 115/230 Vac \pm 17%, 50/60 Hz

† Turbidity specifications determined using USEPA Filter Assembly

‡ Use of a Flow Cell is required to achieve the cited specifications

£ Intermittent Electromagnetic Radiation of 3 volts per meter or greater may cause slight accuracy shifts. See Supplemental Compliance Information on the next page for more information.

SPECIFICATIONS, continued

Displays: 8-character LED, 13.7 mm (0.54 in.) high digits with custom annunciators; 2-character LED, 7.62 mm (0.3 in.) high digits

Light Source: Tungsten filament lamp. Typical lamp life is 8,800 hours.

Signal Averaging: Operator selectable on (selectable from 1-15) or off.

Sample Cells: 95 mm high x 25 mm diam. (3.74 in high x 1 in diameter). Borosilicate glass with rubber-lined screw caps.

Sample Required: 20 mL (1 oz.) minimum

Secondary Standards: Gelex® Secondary Standards

Temperature

Storage Temperature: -40 to 60 °C (-40 to 140 °F)

Operating Temperature: 0 to 40 °C (32 to 104 °F)

Sample Temperature: 0 to 95 °C

Operating Humidity Range: 0 to 90% RH noncondensing @ 25 °C; 0 to 75% RH noncondensing @ 40 °C

Instrument Stabilization Time: 30 min. w/ ratio on, 60 min. w/ ratio off, typical application leaves instrument on 24 hrs/day

Air Purge: 0.1 scfm at 69 kPa (10 psig), hose barb connection for 1/8" tubing, Max 138 kPa (20 psig). Dry nitrogen or instrument grade air (ANSI MC 11.1, 1975)

Power Requirement: 115/230 Vac \pm 17%, 50/60 Hz, 60 VA Max

Serial I/O: RS232 serial interface via DB9 subminiature D shell connector for data output to computer or printer, and data input (command). No handshaking. Factory set for a 1200 baud rate, one stop bit, no parity, eight bit character length. Selectable baud rate (300, 600, 1200, 2400, 4800); character length 7 or 8 bits; stop bits 1 or 2; none, even or odd parity.

Enclosure: High-impact polycarbonate plastic

Dimensions: 30.5 x 40 x 15.6 cm (12 x 153/4 x 61/8 in.)

Instrument Weight: 3.77 kg (8 lbs, 5 oz)

Shipping Weight (with standard accessories): 6.11 kg (13 lbs. 8 oz.)

Supplemental Compliance Information

The Model 2100AN Turbidimeter shows slight accuracy shifts when exposed to radio frequency (RF) fields of 3 volts per meter. If the displayed data are not stable (within the accuracy and repeatability specifications) and other interferences are not suspect, inspect the area for transmitting devices such as portable phones, paging service tower/antennas, or any other transmitting communication device. For example, if a measurement deviation is detected while using a hand held walkie-talkie to relay the information to a control station, the interference clearly is caused by the hand held walkie-talkie. Move the hand held walkie-talkie at least 3 meters from the measuring instrument to provide isolation and resolve the interference problem.

SPECIFICATIONS, continued

As shown below, the instrument reading may deviate slightly in the presence of *specific* frequencies. Any electronic instrument is sensitive to RF fields if the power is great enough. However, typical transmitting power is limited by regulatory controls, and field strengths greater than 3 volts per meter seldom are experienced.

***Points of Susceptibility of the Model 2100AN Turbidimeter
in a modulated electric field of 3 V/m with 80% AM
over a range of 27 Mhz to 1000 Mhz***

Frequency (MHz)	Nominal Value (NTU)	Display Value in RF Field (NTU)	Specification Range (+ 2%) (NTU)
150.0-200.0	0.101	0.084-0.096	0.099 to 0.103
217.0-228.0	0.100	0.075-0.093	0.098 to 0.102
307.0-377.0	0.100	0.084-0.117	0.098 to 0.102
395.0	0.100	0.065	0.098 to 0.102
402.0-550.0	0.100	0.073	0.098 to 0.102
590.0	0.100	0.054	0.098 to 0.102
731.0	0.100	0.090	0.098 to 0.102
791.0-887.0	0.100	0.074-0.124	0.098 to 0.102
930.0	0.100	0.038	0.098 to 0.102
981.0	0.100	0.098	0.098 to 0.102



OPERATION

DANGER

Handling chemical samples, standards, and reagents can be dangerous. Review the necessary Material Safety Data Sheets and become familiar with all safety procedures before handling any chemicals.

DANGER

La manipulation des échantillons chimiques, étalons et réactifs peut être dangereuse. Lire les Fiches de Données de Sécurité des Produits (FDSP) et se familiariser avec toutes les procédures de sécurité avant de manipuler tous les produits chimiques.

PELIGRO

La manipulación de muestras químicas, estándares y reactivos puede ser peligrosa. Revise las fichas de seguridad de materiales y familiarícese con los procedimientos de seguridad antes de manipular productos químicos.

GEFAHR

Das Arbeiten mit chemischen Proben, Standards und Reagenzien ist mit Gefahren verbunden. Es wird dem Benutzer dieser Produkte empfohlen, sich vor der Arbeit mit sicheren Verfahrensweisen und dem richtigen Gebrauch der Chemikalien vertraut zu machen und alle entsprechenden Materialsicherheitsdatenblätter aufmerksam zu lesen.

PERIGO

A manipulação de amostras, padrões e reagentes químicos pode ser perigosa. Reveja a folha dos dados de segurança do material e familiarize-se com todos os procedimentos de segurança antes de manipular quaisquer produtos químicos.

1.1 Instrument Description

The Hach Model 2100AN Laboratory Turbidimeter measures turbidity from 0 to 10,000 NTU (Nephelometric Turbidity Units) with automatic range selection and decimal point placement. Measure solutions with higher turbidity levels by dilution with filtered sample and a simple calculation. Refer to *Section 2.3.7* on page 30 for additional information.

The 2100AN Laboratory Turbidimeter also displays in units of Nephelos (0-67,000 Nephelos), EBCs (European Brewery Convention, 0-2,450 EBCs), % Transmittance, Absorbance or Color Units (APHA Pt-Co Method). In addition, two Application Specific Calibrations may be specified by the analyst. The Application Specific mode uses the Nephelometric optical system in the same manner as the NTU measurement mode. Special method development and sample characterization also can be accomplished using the signal output from any of the four detectors (see Instrument Setup for more information).

Note: Ratio must be on for measurement of samples greater than 40 NTUs, 268 Nephelos and 9.8 EBCs.

The microprocessor-based Model 2100AN is designed for laboratory use, and employs advanced optical and electronic design. The instrument operates on 115/230 Vac, and provides a built-in printer, an RS232 output for connection to a printer, data logger or computer, and a recorder output.

1.2 Standard Accessories

Accessory items supplied with the turbidimeter include six sample cells, a set of StablCal® Sealed Vial Primary Turbidity Standards, a power cord, silicone oil, sample cell oiling cloth, a dust cover, 2 rolls of printer paper (supplied with the 2100AN and 2100AN IS only) and an instrument manual.

1.3 Principle of Operation

The Model 2100AN Laboratory Turbidimeter is a nephelometer with the capability to measure in either Ratio on or Ratio off mode. The instrument meets the design criteria of the United States Environmental Protection Agency (Method 181.1), and is acceptable for compliance reporting.

The optical system* (shown in *Figure 1*) is comprised of a tungsten-filament lamp, lenses and apertures to focus the light, a 90° detector to monitor scattered light, a forward-scatter light detector, a transmitted-light detector, and a back-scatter light detector.

The instrument measures turbidity at less than 40 NTU using only the 90 degree scattered-light detector or using the complete set of detectors (ratio). If the Ratio mode is on, the instrument's microprocessor uses a mathematical calculation to ratio signals from each detector. The benefits of using the Ratio mode for measurements include excellent linearity, calibration stability, wide measurement range, and the ability to measure turbidity in the presence of color.

* U.S. patent 4,198,161.

SECTION 1, continued

Figure 1 Optical Diagram

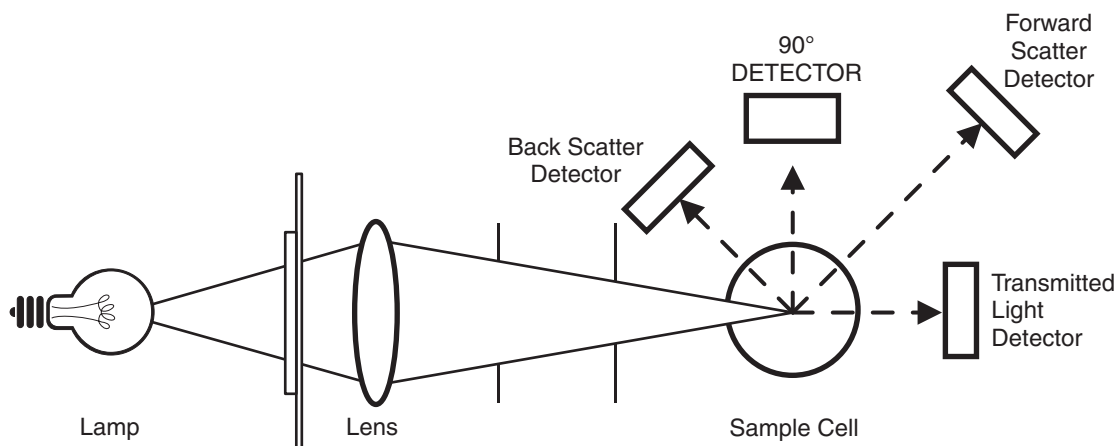

1.4 Preparation for Use

1.4.1 Unpacking

Remove the instrument and accessories from their shipping box and inspect them for damage that may have occurred during shipment due to rough handling or extreme weather conditions.

Verify the following items are present:

- 2100AN Laboratory Turbidimeter
- Instrument Manual with Quick Reference Guide
- A set of StablCal Primary Standards in sealed vials with instructions: Cat. No. 26595-05;
- USEPA Filter Assembly (installed in sample cell compartment) (Cat. No. 30312-00)
- Oiling Cloth—Cat. No. 47076-00
- Six Sample Cells—Cat. No. 20849-00
- Silicone Oil, 15 mL (0.5 oz.) dropping bottle—Cat. No. 1269-36
- Power Cord—Cat. No. 18010-00 (115 V North American use)
Cat. No. 46836-00 (230 V European use)
- Dust Cover—Cat. No. 47030-00
- 2 Rolls of Printer Paper—Cat. No. 47090-00
- 455 nm Filter Assembly—Cat. No. 19998-00

If any of the items are missing or damaged, please contact the Customer Service Department, Hach Company, Loveland, Colorado. Do not return the instrument without prior authorization. In the United States, the toll-free number is 1-800-227-4224. Outside the United States, contact your nearest Hach dealer.

SECTION 1, continued

1.4.2 Operating Environment

Use the turbidimeter in a clean, dust-free environment on a bench or table that is free of vibration and that provides good air circulation around the instrument. Keep the areas in the back and underneath of the instrument case free of materials that could obstruct air flow through the vents.

1.4.3 Operating Power Selection

The instrument is completely assembled when shipped from the factory except for connecting the power cable to the chassis receptacle on the rear panel. Voltage selection for 115 or 230 Vac is done automatically.

A power cord suitable for U.S. and Canadian 115 Vac line voltage is supplied with the Model 2100AN (Cat. No. 47001-00). If this model is to be configured for 230 Vac, an approved UL/CSA power cord with NEMA 6-15P type cord cap must be used in place of the 115V power cord supplied.

The Model 2100AN (Cat. No. 47001-02) is factory configured for European 230 Vac line voltage. The power cord supplied with this model is VDE approved, and has a Continental European type plug.

2.1 Operating Controls and Indicators

2100AN Laboratory Turbidimeter controls and indicators are explained in detail in *SECTION 3* on page 35. Also, refer to Model 2100AN operating features illustrated in *Figure 6* on page 35.

Close the cell cover and press the **I/O** switch on the back instrument panel to turn power on to the 2100AN Turbidimeter. Dark detector readings are taken immediately after the instrument is switched on; error code E7 may be displayed if the cell cover is left open during power up.

2.2 Measuring Turbidity

Measurements may be made with Signal Average on or off, with manual or automatic range selection, and with Ratio on or off. Normally, measurements are made with automatic range selection, Ratio and Signal Average on. When Signal Average is on, the instrument's microprocessor compiles a number of readings and averages the result. The averaged value is calculated and displayed approximately once every second.

WARNING

The 2100AN Laboratory Turbidimeter is not intended for use with flammable samples or those containing hydrocarbons or concentrated acids that might attack the 2100AN components. Conduct compatibility tests prior to analysis if the sample to be monitored is in question.

ATTENTION

Le turbidimètre de laboratoire 2100AN n'est pas prévu pour utilisation avec des liquides inflammables ou contenant des hydrocarbures ou acides concentrés qui pourraient attaquer les composants du 2100AN. Effectuer des essais préalables en cas de doute sur la compatibilité de l'échantillon à contrôler.

ADVERTENCIA

El Turbidímetro de Laboratorio 2100AN no está diseñado para usarse con muestras inflamables o que contengan hidrocarburos o ácidos concentrados que puedan atacar los componentes del 2100AN. Ensaye antes del análisis si existe duda sobre la compatibilidad de la muestra que se intenta analizar.

WARNHINWEIS

Das Labortrübungsmeßgerät 2100AN darf nicht zur Analyse entflammbarer Proben oder Proben, die Kohlenwasserstoffe oder konzentrierte Säuren enthalten, welche die Teile des 2100AN angreifen könnten, verwendet werden. Wenn die Verträglichkeit der zu bestimmenden Probe fraglich ist, sollten vor der Analyse Tests durchgeführt werden.

AVISO

O Turbidímetro de Laboratório 2100AN não é feito com o fim de ser empregado com amostras inflamáveis ou aquelas que contêm hidrocarbonetos ou ácidos concentrados que possam atacar os componentes 2100AN. Os testes devem ser executados antes da análise se existe alguma dúvida com respeito à compatibilidade da amostra a monitorar.

SECTION 2, continued

2.2.1 Nephelometric Measurement Procedure

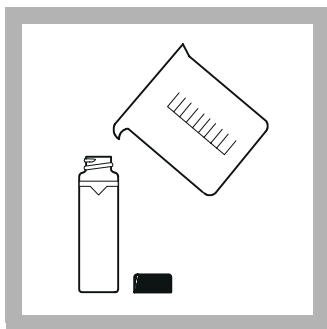

1. Collect a representative sample in a clean container. Fill the sample cell to the line (approximately 30 mL). Handle the sample cell by the top. Cap the sample cell.

Note: Instrument warm-up stabilization time with Ratio on is 30 minutes and with Ratio off is 60 minutes. Typical application is to leave the instrument on 24 hours a day.

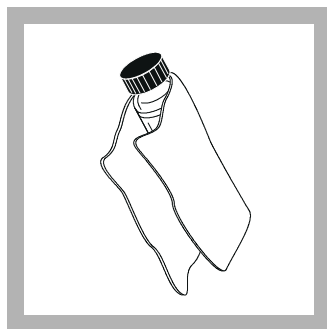

2. Hold the sample cell by the cap, and wipe to remove water spots and finger prints.

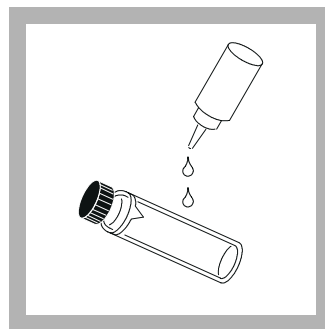

3. Apply a thin bead of silicone oil from the top to bottom of the cell—just enough to coat the cell with a thin layer of oil. Using the oiling cloth provided, spread the oil uniformly. Then wipe off the excess. The cell should appear nearly dry with little or no visible oil.

Note: See Section 2.3.2 on page 22.

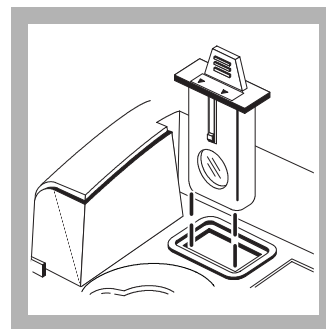

4. Install the appropriate filter module.

Note: The USEPA filter typically is used for this application.

Note: Alternatively, an 860 nm filter can be purchased for non-EPA reporting.

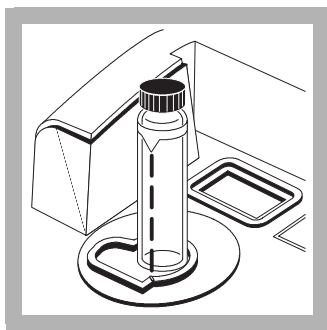

5. Place the sample cell in the instrument cell compartment, close the lid.

Note: For immediate update of the display, press ENTER.



6. Select manual or automatic ranging by pressing the **RANGE** key.

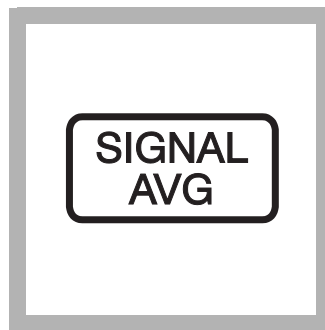

7. Select the appropriate signal averaging setting (on or off) by pressing the **SIGNAL AVG** key.

Note: See Section 3.1.3 on page 38 for more information.

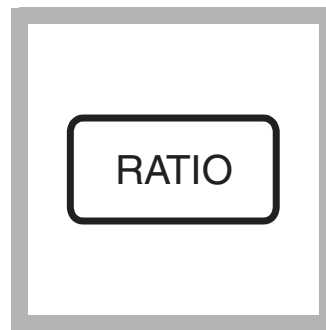

8. Select the appropriate Ratio setting (on or off) by pressing the **RATIO** key.

Note: Values > 40 NTU require Ratio on.

Note: See Section 3.1.6 on page 38 for more information.

SECTION 2, continued

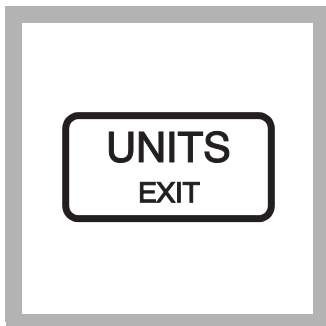

9. Select the appropriate measurement unit (NTU, EBC or NEPH) by pressing the **UNITS/EXIT** key.

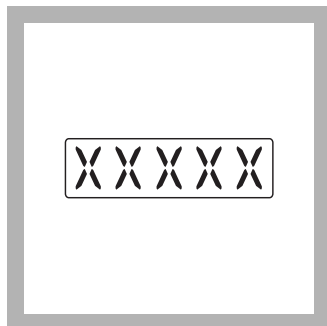

10. Read and record the results.

***Note:** A time- and date-stamped measurement record can be printed or transmitted by pressing the **PRINT** key.*

2.2.2 Measurement Hints

- Always cap the sample cell to prevent spillage of sample into the instrument.
- Always close the sample compartment lid during measurement.
- Install the appropriate Filter Assembly. The EPA Filter Assembly must be installed for measurements requiring EPA reporting.
- Do not leave a sample cell in the cell compartment for extended periods of time.
- Leave the instrument on 24 hours a day if the instrument is used regularly.
- Empty the cell compartment and turn off the power if the instrument is stored for extended periods of time.
- Always use clean, scratch-free sample cells and caps.
- Always apply silicone oil.
- Always observe measurement techniques

SECTION 2, continued

2.3 Measurement Techniques

Accurate and repeatable turbidity measurements depend on good, consistent measurement techniques. Measurements are more accurate and repeatable if close attention is paid to proper measurement techniques. Four important considerations are:

- Use clean sample cells.
- Use sample cells in good condition.
- Remove air bubbles (degassing).
- Apply silicone oil to the sample cell.

Measure samples immediately to prevent changes in sample characteristics due to temperature shifts and settling. Avoid dilution whenever possible; particles suspended in the original sample may dissolve or otherwise change characteristics when the temperature changes or the sample is diluted. Thus, the measurement may not be representative of the original sample.

2.3.1 Cleaning Sample Cells

Cells must be meticulously clean and free from significant scratches. Glass imperfections and superficial scratches from manufacturing are effectively masked by the silicone oiling procedure outlined in *Section 2.3.2*. Clean the inside and outside of the cells by washing thoroughly with a nonabrasive laboratory detergent. Then continue cleaning with a 1:1 HCl bath followed by multiple rinses with distilled or deionized water. Air dry the cells. Handle sample cells by the top only to minimize dirt and fingerprints.

2.3.2 Applying Silicone Oil

Treat the outside of the cells with a thin coating of silicone oil to mask minor imperfections and scratches that may contribute to light scattering. Use only Hach silicone oil (Cat. No. 1269-36); it has the same refractive index as the sample cell glass.

Apply a thin bead of silicone oil from the top to bottom of the cell- just enough to coat the cell with a thin layer of oil. Using the oiling cloth provided, spread the oil uniformly. Then, wipe off the excess so that only a thin coat of oil is left. The cell should appear nearly dry with little or no visible oil. Avoid application of excess oil that may attract dirt, and contaminate the sample compartment of the instrument.

SECTION 2, continued

2.3.2.1 Silicone Oil Procedure

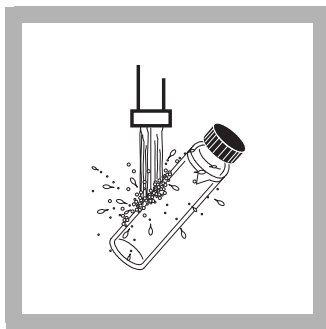

1. Thoroughly clean and rinse the sample cell.

Note: See Section 2.3.1.

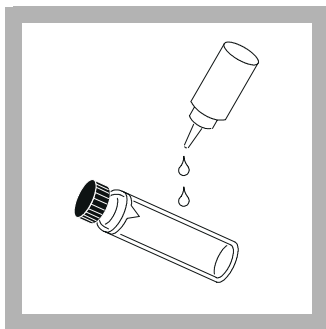

2. Apply a thin bead of silicone oil from the top to bottom of the cell--just enough to coat the cell with a thin layer of oil.

Note: See Section 2.3.2.

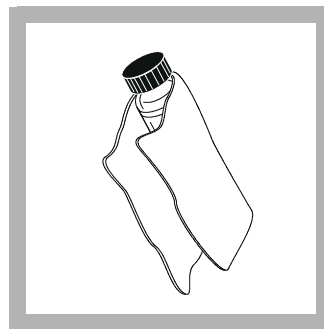

3. Spread the oil uniformly using the oiling cloth provided. Then, wipe off the excess so that only a thin coat of oil is left. The cell should appear nearly dry with little or no visible oil.

Note: Store the oiling cloth in a plastic storage bag to keep the cloth clean.

2.3.3 Preparing Dilution Water

Dilution water may be required for indexing and matching sample cells, diluting over-range samples, and/or preparing Formazin Standards. Collect at least 1000 mL of high quality water (e.g., distilled, demineralized, or deionized water). Check the turbidity of the dilution water before use. The 2100AN may be used to check the dilution water turbidity because the instrument is precalibrated at the factory. If the turbidity is greater than 0.5 NTU, the water may be filtered with a 0.2 micron filter using the Sample Filtration and Degassing Kit (Cat. No. 43975-10) or the equivalent. Clean all glassware with 1:1 hydrochloric acid and rinse several times with dilution water when measuring low range turbidity samples. Cap the cells to prevent small airborne particles from contaminating the glassware if it is not used immediately.

SECTION 2, continued

2.3.3.1 Dilution Water Filtration

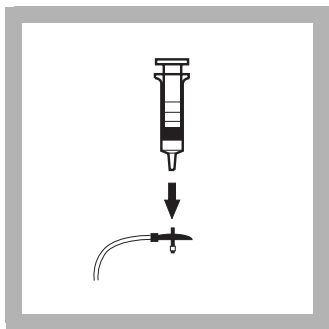

1. Attach the syringe to the 3-way valve by gently twisting the square end into the syringe tip. Attach the connector, tubing and a 0.2 micron filter (clear part faces syringe) as shown. Be sure the connections are tight.

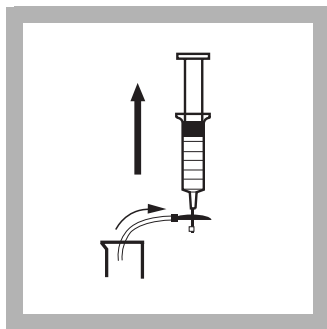

2. Fill a beaker or container with the water to be filtered. Insert the tubing into the container. Slowly draw the water into the syringe by pulling up on the syringe plunger.

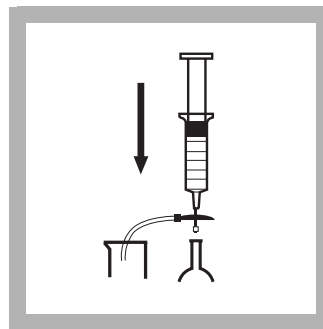

3. Draw about 50 mL of sample into the syringe. Slowly push on the plunger to force the water through the filter and into a graduated cylinder or volumetric flask. Repeat Steps 2 and 3 until obtaining the desired amount of water.

Note: Pushing water through the filter becomes more difficult as the filter clogs. Discard a clogged filter and attach a new filter when necessary. Replacement filters are available in packages of 10 (Cat. No. 23238-10).

2.3.4 Indexing and Matching Sample Cells.

Precise measurement of multiple, low-turbidity samples requires good laboratory techniques to achieve accuracy and good repeatability. Matched sample cells are required to minimize the effects of optical variation among cells. Alternatively, a single sample cell used for every measurement minimizes reading variability caused by cell to cell imperfections. Once cell orientation in the cell holder is established, always use the alignment indicated on the cell, regardless of sample-cell choice (refer to *Section 2.3.4.1* on page 24 and/or *Section 2.3.4.2* on page 26). Using a single cell provides better accuracy and precision than matched cells. A Flow-Cell System provides the best accuracy and reproducibility with the added advantage of sample pour through convenience (see *SECTION 5* on page 55).

2.3.4.1 Indexing a Single Sample Cell

Add an orientation mark to a single sample-cell as follows:

SECTION 2, continued

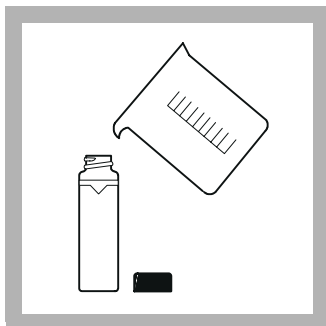

1. Fill the clean sample cell to the line with high-quality water and cap the sample cell (refer to *Section 2.3.3* on page 23).

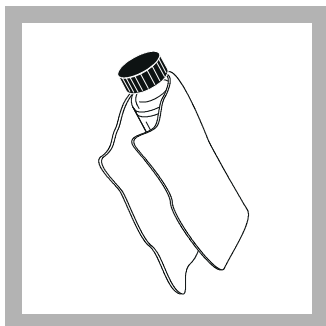

2. Wipe the sample cell clean and apply a film of silicone oil (refer to *Section 2.3.2* on page 22).

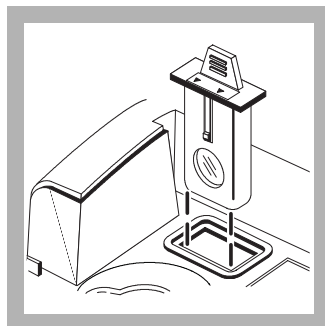

3. Insert the appropriate filter module.

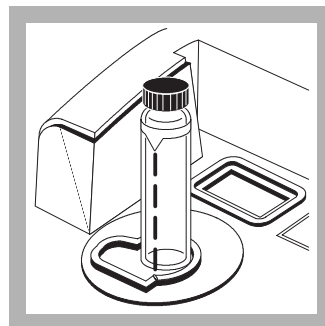

4. Insert the sample cell into the cell compartment and close the cell cover. Record the reading.

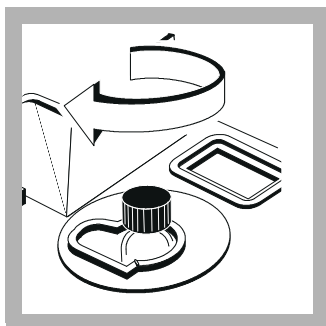

5. Lift the cell compartment cover and rotate the sample cell (approximately $\frac{1}{8}$ of a turn). Close the lid, press **ENTER** and record the reading. Continue this procedure until obtaining the smallest NTU reading.

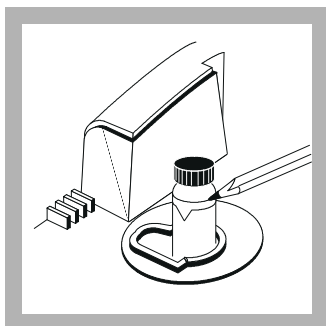

6. Place an orientation mark on the sample cell marking band adjacent to the index mark. Use this mark to align the sample cell each time a measurement is made.

SECTION 2, continued

2.3.4.2 Matching Sample Cells

Index match (orientation) multiple cells using the following procedure. Matched cells also can be used for measuring in Transmittance, Color or Absorbance:

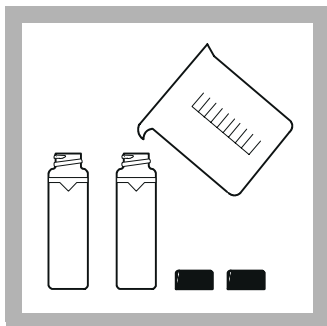

1. Add portions of the high-quality dilution water to multiple cells that are clean and coated with silicone oil (refer to *Section 2.3.1*, and *Section 2.3.2* on page 22, and *Section 2.3.3* on page 23.

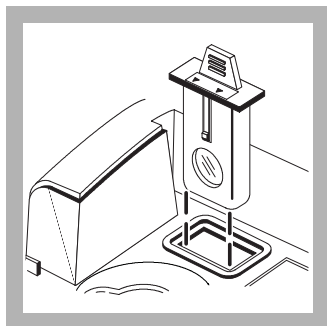

2. Insert the appropriate filter module.

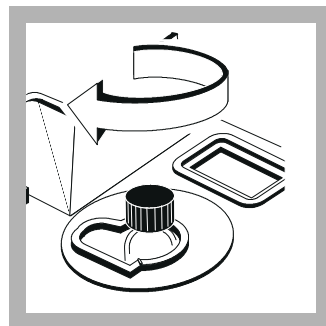

3. Insert the first cell into the instrument. Rotate the cell slightly until the lowest reading is found. Note the cell orientation, record the reading, and add a permanent index mark to the marking band of the cell.

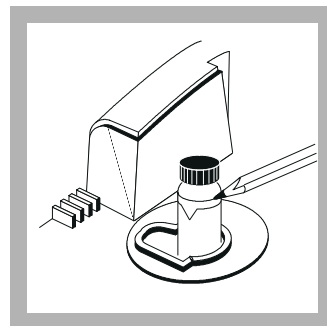

4. Insert the second cell into the instrument, close the lid, and note the value. Rotate the cell about $\frac{1}{8}$ of a turn and observe the reading. Repeat $\frac{1}{8}$ -turn rotations until the reading matches the first cell reading within ± 0.01 NTU. Add a permanent orientation mark to the marking band of the second cell. Repeat this procedure to match other cells.

Note: It may not be possible to match all cells due to variability in glass.

Note: Match sample cells within ± 0.002 absorbance units when indexing cells in the absorbance mode for use with Transmittance, Color or Absorbance measurements.

SECTION 2, continued

2.3.5 Removing Air Bubbles (Degassing)

Remove air or other entrained gases prior to measurement. Degassing is recommended (even if no bubbles are visible). Four methods are commonly used for degassing:

1. Application of a partial vacuum
2. Addition of a surfactant
3. Use of an ultrasonic bath
4. Application of heat.

Sometimes more than one method may be necessary for effective bubble removal (e.g., some severe conditions may require use of heat with an ultrasonic bath). Use care with these techniques; sample turbidity can be altered if these methods are misused.

Letting the sample stand for a period of time to remove air bubbles is not recommended. Particulates that cause turbidity may settle, and the sample temperature may change. Both conditions may alter the turbidity of the sample resulting in a measurement that is not representative of the original sample turbidity.

2.3.5.1 Application of Vacuum

Apply vacuum with any convenient, clean, oil-free vacuum source. The vacuum lowers the atmospheric pressure above the sample allowing trapped gas bubbles to escape. Vacuum works well with non-viscous samples, such as water, that do not contain volatile components. Application of vacuum to viscous, volatile samples (such as paint resins) may cause volatile components to come out of solution, and intensify the bubble problem.

To apply vacuum, use a sample degassing kit equivalent to Cat. No. 43975-00 (Sample Degassing Kit) as shown in *Figure 2* or 43975-10 (*Sample Degassing and Filtration Kit*). These kits contain a syringe and stopper for vacuum degassing. An electric or hand-operated pump equivalent to Cat. No. 14697-00 or 14283-00, respectively, also may be used.

Figure 2 Sample Degassing

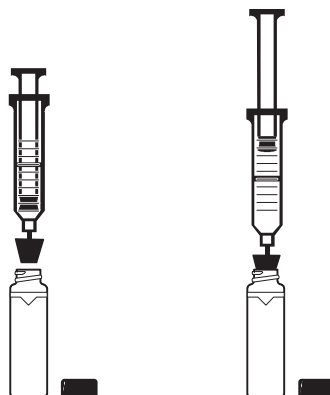

SECTION 2, continued

2.3.5.2 Addition of Surfactant

Limit the use of surfactants (surface-action agents) to severe problems when other degassing techniques prove ineffective. Surfactants change the surface tension of the water causing the release of entrained gases. Hach Company recommends a surfactant such as Triton X-100 (a Rohm and Haas Product, Hach Cat. No. 14096-32) or equivalent. Add one drop of Triton X-100 in the sample cell prior to sample addition.

Note: Any turbidity contributed by the addition of surfactant is negligible.

This technique is particularly effective when water is supersaturated with air. Changing the surface tension may accelerate settling of turbidity-causing particles. Mix the sample well, and measure as soon as possible. Do *not* mix *too* vigorously because the surfactant may begin to foam. Rinse sample cells thoroughly between measurements to prevent accumulation of residual surfactant in the cells.

2.3.5.3 Using an Ultrasonic Bath

An ultrasonic bath (*Cat. No. 24895-00* or equivalent) is effective in removing gas bubbles on most samples, especially on viscous liquids. However, the ultrasonic waves also may alter the characteristics of the turbidity-causing particulates. Turbidity is dependent on the size, shape, composition, and refractive index of the suspended particles. Excess application of ultrasound may alter particle size and shape, and thus change the turbidity. In some instances use of ultrasound may compound the bubble removal task by fracturing gas bubbles, thus making degassing more difficult. Use the following ultrasonic bath procedure.

1. Fill a clean sample cell with sample. Leave the cell uncapped.
2. Immerse the cell ($1/2$ to $2/3$ immersed) in an ultrasonic bath, and allow it to stand until visible bubbles are expelled.
3. Remove the cell and install the cap. Thoroughly dry the cell, and apply a film of silicone oil.

Note: The time necessary to expel bubbles may vary from a few seconds to a minute or more. Follow this simple procedure to avoid excessive application of ultrasound. First, apply ultrasound for a short period of time, and again measure turbidity. Continue for several repetitions noting the treatment time and turbidity readings. If turbidity begins to increase instead of decrease, the ultrasound waves probably have started to alter the suspended particles. Note the treatment time preceding the turbidity increase, and record it as the maximum time limit for ultrasonic treatment.

SECTION 2, continued

2.3.5.4 Application of Heat

WARNING

Make sure the cap on the cell is loose. Heating a tightly-capped cell may result in an explosion.

ATTENTION

Vérifier que le bouchon sur la cuvette est desserré. Le chauffage d'une cuvette bouchée hermétiquement peut provoquer une explosion.

ADVERTENCIA

Cerciórese de que la tapa de la célula esté suelta. Calentar una célula cerrada ajustadamente puede originar una explosión.

WARNHINWEIS

Überprüfen Sie, ob der Verschuß lose auf der Küvette sitzt. Das Erhitzen einer fest verschlossenen Küvette kann eine Explosion verursachen.

AVISO

Tenha certeza de que a tampa na cela esteja solta. O aquecimento de uma cela tapada apertada demais pode ocasionar uma explosão.

Avoid use of heat to accelerate degassing whenever possible. Heat may change the characteristics of the suspended particles, and cause volatile components to come out of solution. Gentle heating may be helpful in degassing very viscous samples when combined with application of vacuum or ultrasound. If heating the sample is necessary, do so only to the extent required to accomplish degassing. Cool the sample to the original temperature before measurement.

2.3.6 Signal Averaging

The signal averaging feature provides compensation for reading fluctuations caused by random drifting particles in the sample. Signal averaging may be turned on or off at any time during measurement by pressing the **SIGNAL AVG** key. When on, the signal averaging annunciator is lighted. The display is updated approximately once every second.

Turning on signal averaging causes measurements (adjustable from 1-15) to accumulate in a measurement buffer. The initial value is displayed immediately. Subsequent values are an average of readings accumulated in the buffer. After measurements are accumulated (approximately 1 measurement per second), the displayed value is a moving average of the specified number of measurements in the averaging buffer. Select a signal average value of 1 for optimum response time. Pressing **ENTER** clears the buffer of all stored values and provides an updated display. If power is turned off and then restored, the instrument defaults to the signal averaging condition selected during the last measurement.

2.3.6.1 Changing SIGNAL AVERAGE Buffer Setting

The 2100AN is shipped from the factory with a default buffer setting of 10 measurements. To change the number of measurements (adjustable from 1-15):

1. Enter the setup mode by pressing **SETUP**. The mode display flashes.
2. Edit the number **09** using the edit keys followed by **ENTER**. Set the number of measurements (1-15) using the edit keys.
3. Press **ENTER** to accept the new setting. Press **SETUP** to return to the measurement mode. Pressing **UNITS/EXIT** at any time, prior to accepting the new value, exits the setup mode leaving original values intact.

SECTION 2, continued

2.3.7 Measuring Over-Range Samples

The nephelometric method of turbidity measurement depends on light scattering from suspended particles. If turbidity is very high, significant amounts of light may be absorbed by the particles, and thus little light is available for scattering. This results in a negative interference; the measured turbidity is lower than the actual turbidity. This condition is called “going blind.” If a sample causes the 2100AN Turbidimeter to “go blind,” the sample may be diluted and re-measured. Or, use a cell adapter and a smaller diameter sample cell to shorten the length of the light path.

Light absorbing particles, such as activated carbon and significant amounts of true color, also may cause an instrument to “go blind.” Dilution may not be effective in correcting for these interferences. The Ratio mode can minimize the effects of light absorbing particles, color, absorbance and high turbidity interferences.

When too much light is absorbed by the sample matrix, sufficient light may not be available for measurement. If this condition occurs, the lamp symbol on the instrument display flashes to warn the user.

2.3.7.1 Sample Dilution

High turbidity samples may be diluted, but avoid this when possible because dilution may alter the characteristics of the suspended particles and produce erroneous results.

When necessary, dilute the sample with a portion of filtered sample. (Diluting with distilled or deionized water may dissolve some of the turbidity.)

Filter samples with the Sample Filtration and Degassing Kit (*Cat. No. 43975-10*) shown in *Figure 3*. If the filters in this kit plug too rapidly, use a standard 47 mm filtration apparatus illustrated in *Figure 4* with a membrane filter (*Cat. No. 13530-01*), or use a glass-fiber filter (*Cat No. 2530-00*) for very high solids. After dilution and measurement, calculate the actual result as follows:

1. Calculate the dilution factor

$$\text{Dilution Factor} = \frac{\text{Total Volume}}{\text{Sample Volume}}$$

Where total volume = sample + dilution water

Example: 20 mL of sample + 80 mL of dilution water = 100 mL total

$$\text{Dilution Factor} = \frac{100}{20} = 5$$

2. Calculate the Final Turbidity Value:

Measured Result x Dilution Factor = Actual NTU

For example, if the measured turbidity value is 2450 NTU, the final turbidity value is calculated as:

$$2450 \times 5 = 12250$$

SECTION 2, continued

Figure 3 Filtering Apparatus

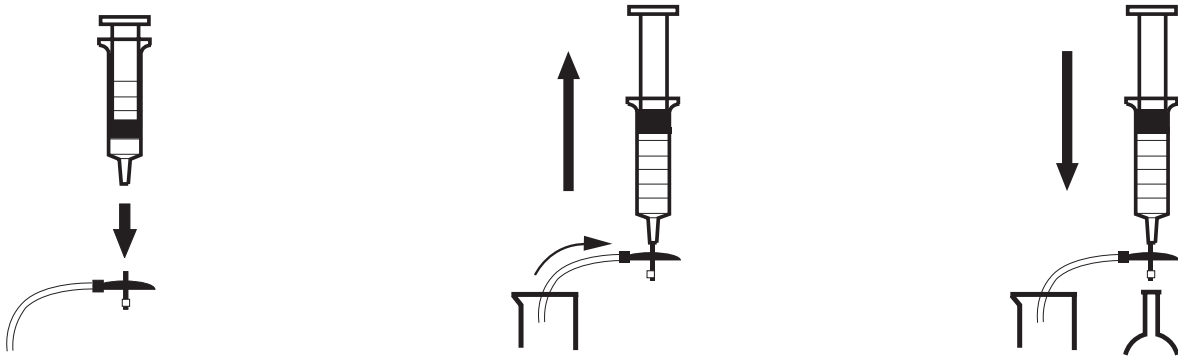
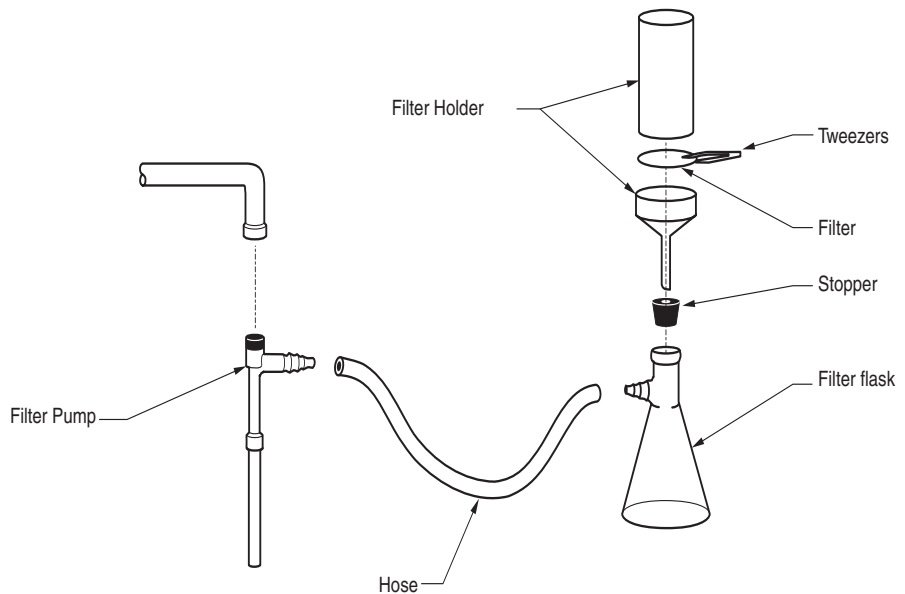

Figure 4 Sample Filtering



2.3.7.2 Using Cell Adapters

Cell adapters are used with the Model 2100AN Turbidimeter when sample cells smaller than the standard 25-mm cells are required. A wide variety of test tubes, sample cells and ampules can be used with the cell adapters. Small diameter sample cells are useful with the instrument when only a small quantity of sample is available, the sample to be measured is in an ampule and cannot be opened, or the sample is too turbid for use with the standard sample cell. A shorter light path permits measurement of high-range samples without the need for sample dilution.

Adapters are available for test-tube diameters of 12- to 13-mm, 16-mm and 19-mm O.D. The 12- to 13-mm adapter accommodates either 12-mm or 13-mm tubes. The minimum sample volumes that must be used are 2.5 mL for 12-mm tubes, 3.5 mL for 13-mm tubes, 5 mL for 16-mm tubes and 7 mL for 19-mm tubes.

SECTION 2, continued

Note: The 2100AN reads slightly different with cell adapters installed because of the shorter path length associated with the smaller diameter sample cells. Refer to the instruction sheet sent with the cell adapters for additional information.

The adapters come with a tall light shield supplied for test tubes taller than the standard cover.

Carefully select sample-cell glassware used with the adapters to be clean and free of significant scratches. The same handling and cleaning care applied to the standard 2100AN sample cells applies to the smaller cells (including the use of silicone oil on the outside of the glass).

Use the *Application Specific Calibration (ASC)* ability of the instrument to provide direct reading of results with cell adapters installed (instead of developing a new calibration curve each time a cell adapter is used).

2.3.7.3 Installing and Removing Cell Adapters

Align the tab on the cell adapter toward the front of the instrument to install in the instrument's sample compartment (see *Figure 5*).

Note: Do not force the adapter out of the compartment; serious instrument damage can occur.

Carefully pull the adapter straight up to remove. Slowly rotate the adapter 90-degrees counter-clockwise if the adapter catches.

Figure 5 Cell Adapter Installation

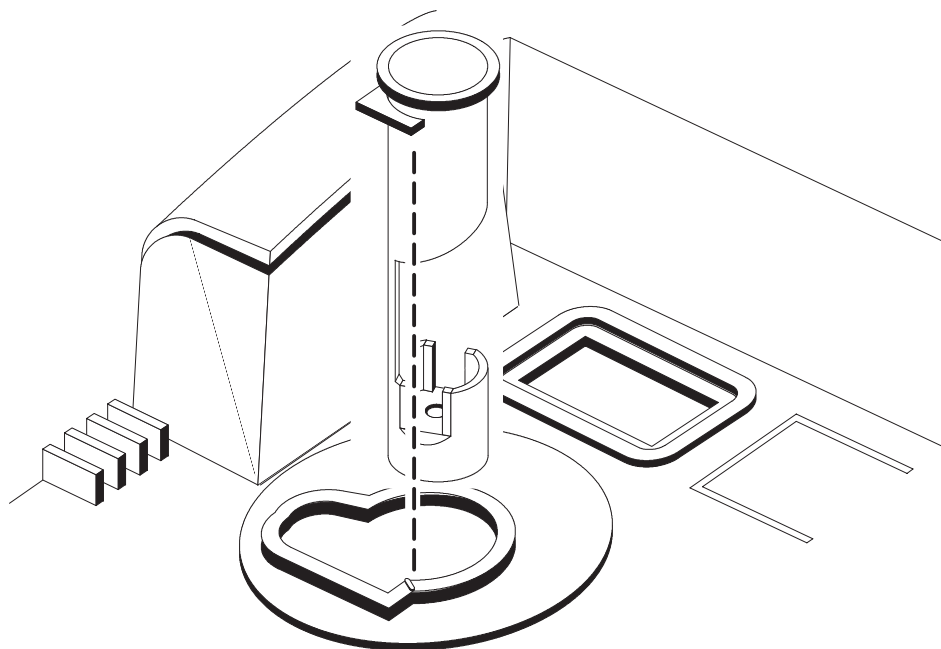

SECTION 2, continued

2.3.8 Condensation (Fogging)

Note: Warming may alter the sample turbidity. Measure the sample without warming whenever possible.

Condensation may occur on the outside surface of a sample cell when a cold sample is being measured in a warm, humid environment. This condensation or fogging of the sample cell interferes with turbidity measurement. Make sure all moisture is thoroughly wiped from the outside of the sample cell prior to placing the cell in the instrument for measurement. When condensation is probable, use the air purge feature of the 2100AN. Refer to *SECTION 4* on page 53 for instructions on connecting and using air purge. If condensation persists even with air purging, it may be necessary to warm the sample slightly by letting it stand at room temperature or by partially immersing it in a warm water bath for a short period of time. Make sure samples are well mixed before measurement.

2.3.9 Calibration Check

Quickly and easily verify the calibration of your 2100 Series Turbidimeter using the included StablCal Sealed Vials. Simply select the vial closest to the range being measured (do not use the <0.1 NTU vial—it does not have a precisely defined NTU value).

Prepare the vial as described in Section 3.2.5 *Handling StablCal® Sealed Vial Standards*. Insert the vial in the cell holder and read the value. If the value is within $\pm 10\%$ of the stated vial value, the instrument calibration is valid for reporting purposes. If the reading is not within $\pm 10\%$, re-calibrate the instrument.

2.3.10 Representative Sampling

A representative sample accurately reflects the true conditions of the source from which the sample was taken. To ensure a representative sample, gently but thoroughly mix every sample before collecting aliquots (sample portions). Do not allow particles to settle before making measurements.

Note: Mix by gentle inversion only. DO NOT SHAKE.

Run water for at least five minutes before sampling from a water tap in a distribution system or treatment plant. When sampling from a body of water (e.g., a stream, reservoir, clarifier or storage tank), collect at least one liter (1 quart), and thoroughly mix before taking an aliquot for measurement. If the sample source is not uniform, it may be necessary to sample several locations at varying depths, and combine the samples into a single, well mixed composite sample before measurement.

3.1 Operational Controls and Indicators

Figure 6 illustrates the locations of all controls, indicators and other operational features of the Model 2100AN Laboratory Turbidimeter. Information on the functions of each of these features is provided in Table 1 and supplemented with additional details in sections Section 3.1.1 through Section 3.1.11.

Figure 6 Model 2100AN Operating Features and Functional Descriptions

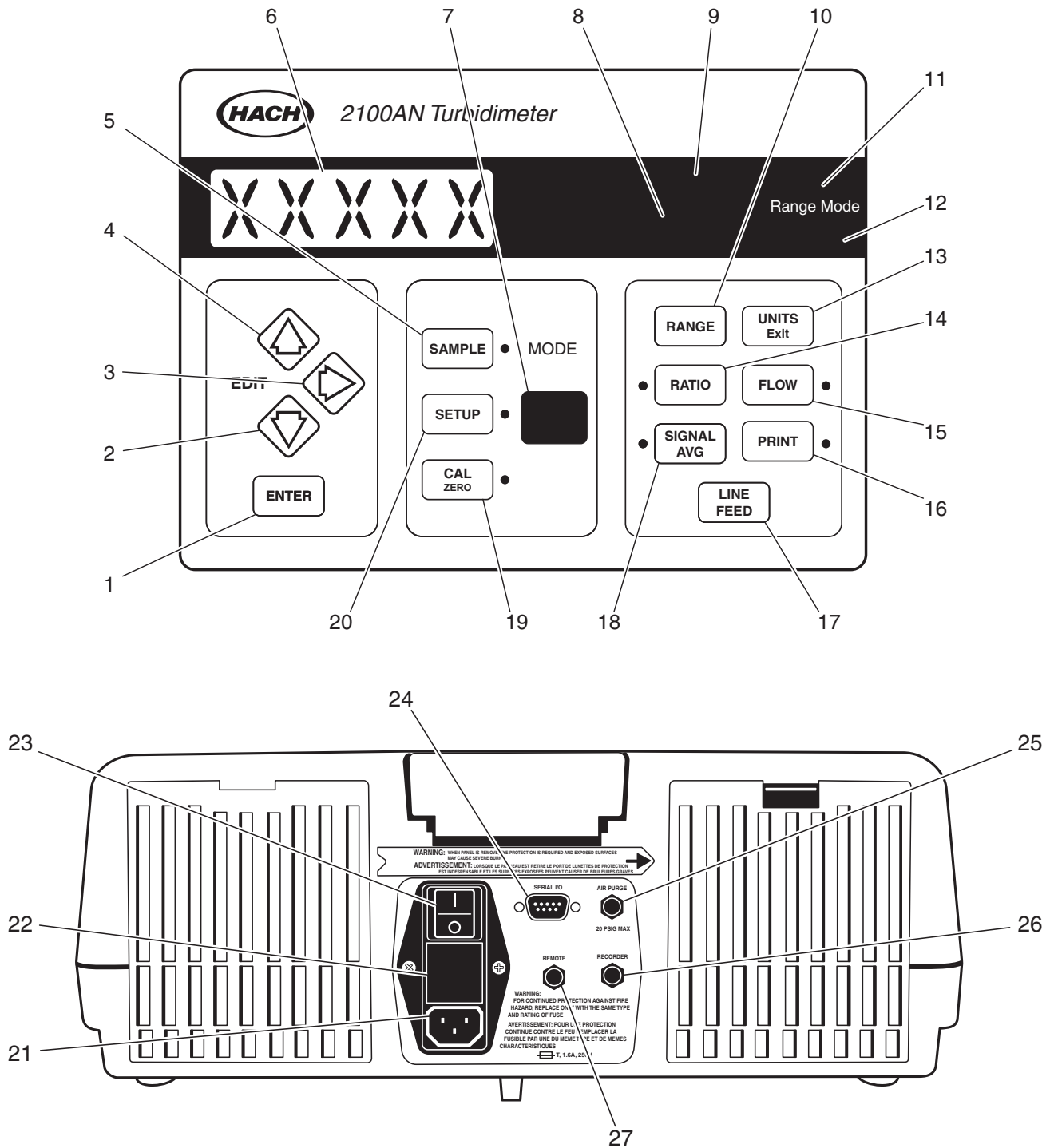

SECTION 3, continued

Table 1 Operating Features and Functional Descriptions

Item	Name	Description
1	ENTER	Used in Calibration Mode to select the value of the Formazin calibration standard and to initiate measurement of the standard. Pressing ENTER during measurement with Signal Averaging on clears the buffer of all previous data. Selects functions during instrument setup and Flow-Cell setup. Selects an edited sample number. Initiates zeroing in the Color Unit mode. Initiates zeroing measurement in the %T and Absorbance modes.
2	Down Arrow	Same as the up arrow except for direction of steps.
3	Right Arrow	Advances the cursor position during calibration standard editing, instrument setup and sample number selection. Also, used to ignore dilution water turbidity during calibration (if required).
4	Up Arrow	Edits LED digits in the calibration mode and steps through calibration standards 00 through 05 (in the mode display). Edits the "SETUP" number (in the mode display) during the instrument setup procedure. Increments the sample number (in the mode display).
5	SAMPLE	Initiates editing of the sample number shown in the Mode display (green LED). Annunciator lights to indicate Sample mode is selected.
6	Display	Eight-digit LED display.
7	Mode Display (green 2-digit LED)	Displays calibration standard number, setup parameter number or sample number. Pressing the up or down arrow key increments or decrements the sample number by one during measurement mode. The sample number is included on the time- and date-stamped measurement printout. (The sample number also is edited by pressing the SAMPLE key.)
8	Lamp	Lighted annunciator indicates when the instrument lamp is on. Flashes to indicate a low-level light condition.
9	CAL?	Lights to indicate the calibration information recorded during the calibration process is outside of the acceptable range (may be an operator calibration error or an instrument malfunction). The instrument must be recalibrated if the CAL? annunciator flashes.
10	RANGE	Selects Auto Ranging or Manual Ranging. Pressing RANGE steps the instrument through the range options.
11	Manual Range	Lighted annunciator indicates when the instrument is in the manual ranging mode.
12	Auto Range	Lighted annunciator indicates when the instrument is in the automatic ranging mode.
13	UNITS Exit	Selects unit of measure. Available options are NTU, EBC, NEPH, %T, Absorbance, CU and two ASC (Application Specific) units. Also, exits calibration or setup without saving new values.
14	RATIO	Turns ratioing on or off [only in NTU, EBC, NEPHLO, or ASC modes with <40 NTU (or equivalent) samples]. Lighted annunciator indicates ratioing is on. Flashes to indicate over-range of 40 NTU in ratio off mode.
15	FLOW	Enters or exits automated flow mode used with the automated Flow-Cell system. Lighted annunciator indicates that the flow mode of operation is on. A flashing annunciator indicates that the flow cycle is complete.
16	PRINT	Transmits the result of measurement to a computer or printer. If the instrument is in the calibration review mode, pressing PRINT transmits calibration data to a printer or computer. If the PRINT key is held during power up, a full set of diagnostic results is transmitted to a computer or printer. Pressing the print key while editing a setup number prints a summary of the setup commands.
17	LINE FEED	Advances the internal printer paper one line each time the key is pressed.
18	SIGNAL AVG	Turns the signal averaging function on or off. Lighted annunciator indicates Signal Averaging mode is on.
19	CAL Zero	Initiates calibration in NTU, EBC, NEPH and ASC measurement modes. Initiates analytical zeroing in CU (Color Units) calibration and operational modes. Initializes analytical zeroing in %Transmittance and Absorbance modes.
20	SETUP	Initiates editing of the setup number to configure the instrument for specific operational functions (e.g., keyboard beeper on or off, print interval, date and time, Signal Averaging, etc.).
21	Power Cord Receptacle	Connection for line power cord. Must be correct rating for line voltage used.

SECTION 3, continued

Table 1 Operating Features and Functional Descriptions (continued)

Item	Name	Description
22	Fuse Holder	Contains two time-delay, 1.6 amp, 250V fuses suitable for either 115- or 230-volt operation.
23	I/O	Power switch turns instrument on and off.
24	Serial Interface Connector	DB9 connector for RS232 cable connection.
25	Air Purge Fitting	Connection for air purge tubing. Maximum pressure 138 kPa (20 psig).
26	Recorder Output Jack	Provides 0-1 volt output for operation with a chart recorder.
27	Remote Cable Jack	Flow-Valve Module connection for automated Flow-Cell Kit operation (low pressure).
(not shown)	Light Shield	Covers sample cell compartment to eliminate light that would interfere with the measurement. <i>Must be closed during measurement, calibration and at power on; keep closed except when inserting sample cell.</i>
(not shown)	Cell Holder	Holds sample cell with solution to be measured. The reference mark is used to align the sample cell for proper orientation in the cell holder.

3.1.1 Using the RANGE Key

Refer to *Section SPECIFICATIONS* for the instrument ranges. Select automatic or manual ranging by pressing the **RANGE** key. Repeated presses step the instrument from automatic range to manual range and then through each of the four manual range settings. When automatic ranging is selected, the Auto Range annunciator lights. In manual ranging, the Manual Range annunciator lights. The instrument defaults to auto ranging during calibration. Range selection may be made at any time during sample measurement. If the instrument is turned off, it defaults to the last selected range setting when power is restored to the instrument.

The display flashes all 9s or all 0s when the sample being measured is over-range or under-range, respectively. Press the **RANGE** key to select the proper measurement range. If the over-range display flashes in Automatic Ranging or in the highest Manual Range, the sample is over-range for the instrument and must be diluted prior to measurement (refer to *Section 2.3.7* on page 30).

For samples in excess of 40 NTUs, 268 Nephelos, 9.8 EBCs, or equivalent Application Specific units, the display flashes 9s to indicate over-range if the **RATIO** mode is off. Ratioing must be on to measure samples above these levels.

3.1.2 Using the UNITS/Exit Key

This key selects the unit of measure. In addition, the **UNITS/Exit** key returns the instrument to the Sample mode (measurement) from any other software location. If power is interrupted, the instrument returns to the last selected unit of measure when power is restored.

Press the **UNITS/Exit** key repeatedly until the desired unit of measure is displayed. The units are displayed in the last three positions of the LED display.

The **UNITS/Exit** key also exits calibration without saving new values; previously stored calibrations are saved. Calibration information can be reviewed by entering the calibration mode, and then exited without changing the stored calibration data. Also, if an error is made during calibration, pressing the **UNITS/Exit** key escapes the calibration routine without saving the new data.

SECTION 3, continued

3.1.3 Using the SIGNAL AVG Key

Turning on Signal Averaging causes a number of measurements to accumulate in a measurement data storage buffer. The number of measurements stored and used for displaying the average reading can be specified by the analyst (between 1 and 15 readings). Three measurements are averaged with Signal Averaging off. The initial value is updated immediately with Signal Averaging on. Subsequent values are an average of readings accumulated in the buffer. As the buffer accumulates the number of readings specified, the display shows the cumulative average.

Press **SETUP** to change the number of readings used for the Signal Averaging mode (set at 10 initially). One of the green LED digits in the mode display begins to flash. Press the up, down and right arrow keys to select the setup number **09**. Press **ENTER**. Next, enter the number of signal averages using the edit keys. Press **ENTER** to accept the number of readings displayed. Press **SETUP** to exit the setup mode. Pressing **UNITS/Exit** at any time, prior to accepting the new value, exits the setup mode leaving original values intact. The largest acceptable Signal Averaging number is 15; the instrument uses 15 measurements if a larger number is specified.

Pressing **ENTER** when Signal Averaging is selected on clears the data buffer and provides an immediate update. If power is turned off and then restored, the instrument re-initializes to the Signal Averaging condition selected during the last measurement.

3.1.4 Using the FLOW Key

Press the **FLOW** key to enter or exit the automated **FLOW** mode that is used in conjunction with the automated Flow-Cell system. Refer to *Section 5.2.2* on page 60 for more information.

3.1.5 Using the LINE FEED Key

Press the **LINE FEED** key to advance the internal printer paper one line each time the key is pressed.

3.1.6 Using the RATIO key

Turn Ratio on and off by pressing the **RATIO** key. A lighted annunciator indicates the Ratio function is selected on. A flashing annunciator light and 9s on the large LED display indicate that the measurement is greater than 40 NTUs and the Ratio mode is selected off. Press the **RATIO** key to clear the over-range condition; the Ratio annunciator is lighted.

With Ratio on, the 90°, transmitted and forward scatter detectors are used to make the measurement. When NTU values greater than 4000 are measured, the back scatter detector signal is incorporated into the measurement.

Measurements with Ratio on and measurements with Ratio off are nearly equivalent for turbidity measurements less than 40 NTU if interferences due to color or light absorbing particles are not present. However, Ratio on compensates for instrumental and sample variables. Operation with Ratio on is recommended for most measurements. Refer to *Section 1.3* on page 15 for a more detailed discussion of Ratio on vs. Ratio off measurements.

SECTION 3, continued

3.1.7 Using the PRINT Key

The **PRINT** key initializes several data transmittal activities. Press the **PRINT** key to print the displayed value, units of measure, sample number, and time and date to the internal printer and/or RS232 output. See *Section 6.4.2* on page 77 for detailed setup instructions.

A print interval can be specified using the instrument setup protocol (see *Section 6.4.2.3* on page 77). Press the **PRINT** key to initiate the print interval after it is selected. The **PRINT** annunciator flashes to indicate a print interval is specified but not started. The annunciator lights when a print interval setup is being executed.

A calibration data report is generated by pressing the **PRINT** key when in the Calibration mode. Holding the **PRINT** key down while turning on instrument power prints a diagnostic report. The report can be transmitted to an external printer or computer if the external RS232 output is selected. Pressing the **PRINT** key while in the setup mode prints a report referencing setup functions to setup numbers.

3.1.8 Using the CAL/Zero Key

A (Nephelometric) calibration is initiated by pressing the **CAL/Zero** key when working in the NTU, EBC, NEPH or Application Specific measurement modes. The unit of calibration is NTU based on Formazin. Refer to *SECTION 10* on page 91 for detailed instructions.

Pressing **CAL/Zero** at the end of a calibration sequence saves new calibration values and the instrument returns to the last-used measurement mode. Refer to *Section 3.2.4* on page 43 for detailed calibration instructions.

Pressing the **CAL/Zero** key while in the %T, Absorbance, or color mode begins the “analytical zero” (100 %T, 0.0 Absorbance, or 0.0 CU respectively). Install a sample cell containing the reference solution and press **ENTER**. The instrument counts from **30** to **0** while the “analytical zero” is in progress.

3.1.9 Using the ENTER Key

Press the **ENTER** key to accept the displayed or edited setup information or to begin measurement of a calibration standard.

Pressing the **ENTER** key clears stored data from the Signal Averaging memory buffer and quickly updates the display when measuring samples. This feature is useful particularly when measuring samples with large differences in Turbidity.

3.1.10 Using the Arrow Keys

The up, down and right arrow edit the displayed value during calibration and increment through the calibration standards. They also edit the display any time an individual digit is flashing. Therefore, the arrow keys are referred to as edit keys.

The right arrow key also can be used during calibration to ignore the dilution water turbidity standard (Standard **00**). This procedure is not recommended except in special applications. Refer to *Section 3.2* through *Section 3.3.4* for details.

SECTION 3, continued

3.1.11 Using the **SAMPLE** Key

Press the **SAMPLE** key to begin editing the sample number shown in the Mode display (green LED). The annunciator next to the key lights to indicate that the **SAMPLE** mode is selected.

3.1.12 Using the **SETUP** Key

Press the **SETUP** key to begin editing the setup number to configure the instrument for specific operational functions (e.g., keyboard beeper on or off, print interval, date and time, signal averaging, etc.). After the setup key is pressed, pressing the **PRINT** key prints a list of the setup numbers along with their setup commands.

3.1.13 Key Annunciator Tone (Beeper)

The key annunciator tone (beeper) is selectable on or off. When the mode is selected on, each key press is acknowledged by an audible “beep.” The instrument is shipped with the tone on. To turn the tone off or on, use the following procedure:

Press the **SETUP** key. The annunciator lights and one of the two small green LED digits in the mode display begins to flash. If the display does not read **00**, use the edit keys to select **00**. Press **ENTER**. The display reads **BEEP ON** or **BEEP OFF**. Use the up or down keys to display the desired operational mode. Press **ENTER** to accept the setting. Press **SETUP** to exit the setup mode. Pressing **UNITS/Exit** at any time, prior to accepting the new setting, exits the setup mode leaving original setting intact.

3.2 Calibration

The electronic and optical design of 2100 Series turbidimeters provide long-term stability and minimize the need for frequent calibration. The multi-detector ratio optical system compensates for electronic and optical system variations between calibrations.

Hach recommends calibrating the instrument before it is used for the first time. When data is used for USEPA reporting, recalibrate at least every 90 days, or as stipulated by the regulating authority. Periodically, as experience or regulating authorities indicate, verify the instrument calibration using one of the StablCal[®] standards supplied with the instrument. If the reading in the range of use is not within 10% of the standard’s assigned value, recalibrate the instrument.

Note: For maximum accuracy and ease-of-use, your Hach turbidimeter is supplied with a StablCal Calibration set. The set contains prepared, stabilized formazin suspensions in specially sealed vials.

Note: The calibration is based on a first order linear equation consisting of up to four independent variables. Unpredictable results may occur if standards other than the recommended calibration points are used. The factory suggested calibration points have been determined by Hach Company chemists and engineers to provide the best calibration accuracy. Use of standards other than StablCal, or user-prepared formazin may result in less accurate calibrations.

SECTION 3, continued

3.2.1 Formazin Stock Solution

Make Formazin dilutions used for instrument calibration from a 4000-NTU stock solution equivalent to the Hach Cat. No. 2461-49 turbidity standard supplied with the instrument. This prepared stock solution is stable for up to one year from the date received when properly stored. Thoroughly mix the 4000-NTU stock solution prior to use for making standards. If desired, 4000 NTU stock solution can be prepared using hydrazine sulfate and hexamethylenetetramine (also available from Hach). Hach Company recommends using the prepared standard for best accuracy and long term data comparability. Preparation of 4000 NTU stock solution from raw materials is temperature and technique dependent. Prepared stock solution from Hach is manufactured under the tightest quality control standards. Formazin product purchased in the future will be equivalent to the standard delivered with the new instrument. Refer to *Section 3.2.7* on page 49 for preparation instructions.

3.2.2 Dilution Water

Use high-quality, low-turbidity water (<0.5 NTU) to prepare the Formazin dilutions required to calibrate the instrument. The 2100AN Turbidimeter provides automatic correction for <0.5 NTU turbidity contributed by dilution water (refer to *Section 2.3.3* on page 23).

Distilled, demineralized or deionized water usually is sufficient, as is most filtered tap water. If the purified water exceeds 0.5 NTU, filter it to meet the turbidity requirements as described in *Section 2.3.3.1* on page 24.

3.2.3 Preparing Recommended Formazin Dilutions

Note: *Instead of diluting a formazin stock solution, StablCal® stabilized formazin suspensions may be used. Order StablCal Calibration Kit for the 2100AN Turbidimeter, Cat. No. 26595-00 (bottled) or Cat. No. 26595-05 (ampuled).*

Hach Company recommends use of 20-, 200-, 1000- and 4000 and 7500-NTU Formazin standards for calibration of the Model 2100AN Turbidimeter. Prepare Formazin dilutions immediately before calibration, and discard the dilutions after use. While 4000-NTU stock solutions are stable for up to one year, diluted solutions deteriorate more rapidly. Prepare dilutions of 20, 200 and 1000 NTUs according the directions in *Table 2*. The dilution water also is used to make an initial blank measurement.

Note: *When measuring turbidity less than 4000 NTU, the 7500 NTU calibration data point does not have to be included in the instrument calibration. After measuring the 4000 NTU standard, press **CAL/Zero** to complete the calibration procedure, store the other 5 calibration data points and return to the measurement mode.*

The 7500-NTU Formazin standard is provided in an ampule ready for use. Do not open the ampule or use the contents as dilution stock. The standard is stable for one year from the date it is received. Replace this calibration standard annually.

SECTION 3, continued

Table 2 Formazin Standard Preparation

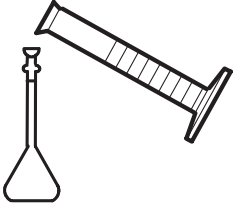
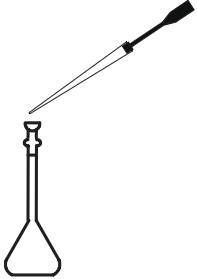
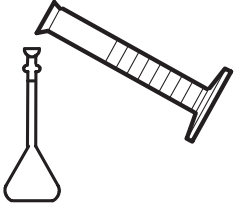
Standard	Step 1	Step 2	Step 3
			
20 NTU	Add 100 mL of dilution water to a clean 200-mL class A volumetric flask	With a TenSette®* Pipet, add 1.00 mL of well-mixed 4000-NTU Formazin stock solution to the 200-mL flask.	Dilute to the mark with dilution water. Stopper and mix.
200 NTU	Add 50 mL of dilution water to a clean 100-mL class A volumetric flask	With a TenSette* Pipet, add 5.00 mL of well-mixed 4000-NTU Formazin stock solution to the 100-mL flask.	Dilute to the mark with dilution water. Stopper and mix.
1000 NTU	Add 50 mL of dilution water to a clean 100-mL class A volumetric flask	With a TenSette* Pipet, add 25.00 mL of well-mixed 4000-NTU Formazin stock solution to the 100-mL flask.	Dilute to the mark with dilution water. Stopper and mix.
4000 NTU	Transfer approximately 30 mL of well mixed 4000-NTU Formazin stock solution to a clean sample cell. No dilution is required.		
7500 NTU Ampule	Use in the sealed ampule as provided. DO NOT open the vial or use its contents as dilution stock.		

* Class A volumetric pipets can be used in place of a TenSette Pipet.

Note: Install each cell with the orientation mark aligned with the cell holder reference mark when using matched vials.

SECTION 3, continued

3.2.4 Calibrating the 2100AN (using Formazin Standards)

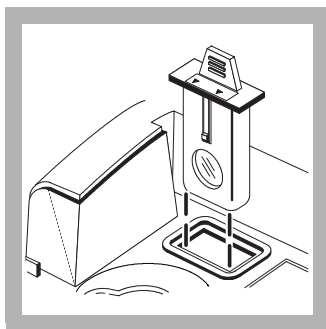

1. Insert the EPA filter module.

Note: Clean the filter before performing a primary calibration, or at least every 3 months (which is the USEPA recommended calibration frequency).

Note: To clean the filter, use glass cleaner, lens cleaner, or isopropyl alcohol, and a cotton-tipped swab.



2. Press **CAL/Zero**.

The CAL mode annunciator lights, and the small green LED digits in the mode display flashes **00**. The NTU value of the dilution water used in the previous calibration is displayed.

Note: Ratio on and Ratio off calibration data are measured and recorded simultaneously.

Note: Calibration for EBC and NEPH units of measure is set automatically via the NTU calibration.

Note: Upon entering the Calibration Mode, Automatic Range, Signal Averaging On, Ratio on and NTU units are automatically selected. Upon completion of calibration, all operational modes are restored to precalibration settings.

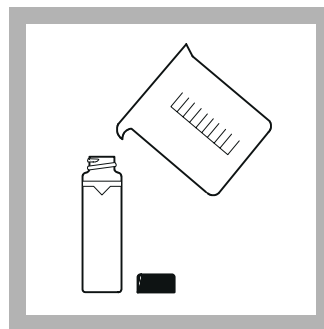

3. Fill a clean sample cell to the line (approx. 30 mL) with dilution water. Wipe the cell clean and apply a thin film of silicone oil (refer to Section 2.3.2 on page 22).

Note: For best accuracy use matched sample cells for all measurements during calibration (refer to Section 2.3.4.2 on page 26). An alternative may be to use the same cell for all standards.

Note: A portion of the same dilution water used for preparing standards must be used in this step.

Note: To exit the calibration procedure at any time without changing any stored value, press **UNITS/Exit**.

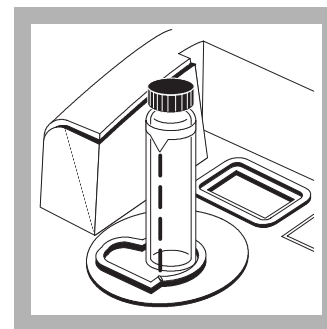

4. Place the sample cell into the cell holder, and close the cell cover.

Note: Install all matched vials with the orientation mark aligned with the cell holder reference mark.

SECTION 3, continued

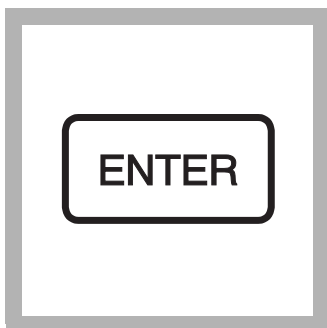

5. Press **ENTER**.

The instrument display counts down from **60** to **0**, and then makes a measurement. This result is stored and used to calculate a correction factor for measurement of all NTU standards.

Note: If reading of dilution water is >0.5 NTU, an **E1** error message is displayed at the end of step 11.

Note: The turbidity of the dilution water can be "ignored" rather than reading the dilution water. Refer to Section 3.3.1 on page 50.

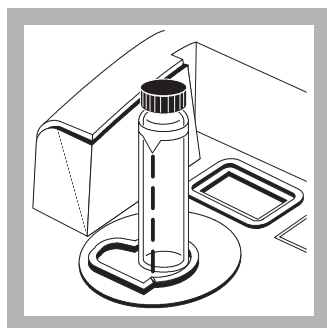

6. The instrument automatically increments to the next standard, displays the expected NTU value (e.g., 20.00 NTU), and the standard number **01** is shown in the mode display. Remove the sample cell from the cell holder.

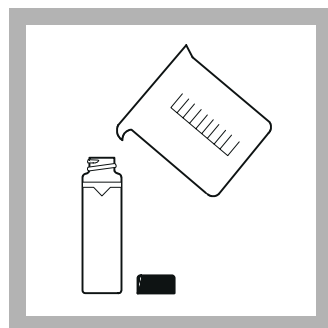

7. Fill a clean sample cell to the line with well-mixed, 20-NTU Formazin standard. Wipe the sample cell clean, and apply a thin film of silicone oil on its surface. Place it into the cell holder, and *close the cell cover*.

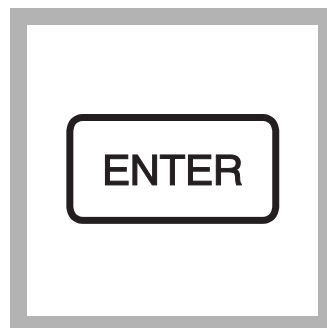

8. Press **ENTER**.

The display counts down from **60** to **0**, and takes a measurement. The instrument applies a correction factor to compensate for turbidity of the dilution water. The instrument automatically increments to the next standard, the display shows 200.0 NTU, and the standard number **02** is displayed. Remove the sample cell from the instrument.

SECTION 3, continued

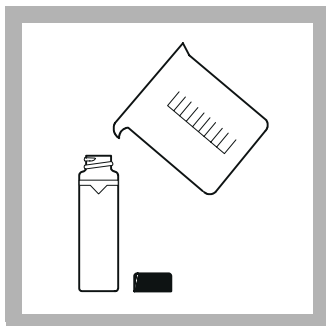

9. Fill a clean sample cell to the line with well-mixed, 200-NTU Formazin standard. Wipe the cell clean and apply a thin film of silicone oil to the surface. Place it into the cell holder, and *close the cell cover*. Press **ENTER**.

The instrument display counts down from 60 to 0, and then makes a measurement. The instrument automatically increments to the next standard, the display shows 1000 NTU, and the standard number 03 is displayed. Remove the sample cell from the instrument.

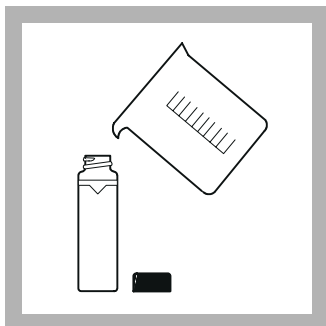

10. Fill a clean sample cell to the line with well-mixed, 1000-NTU Formazin standard. Wipe the cell clean and apply a thin film of silicone oil to the surface. Place it in the cell holder and *close the cell cover*. Press **ENTER**.

The instrument display counts down from 60 to 0, and then takes a measurement. The display automatically increments to the next standard, the display shows 4000 NTU, and the standard number 04 is displayed. Remove the sample cell from the instrument.

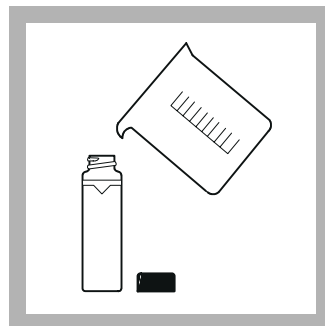

11. Fill a clean sample cell to the line with well-mixed, 4000-NTU Formazin standard. Wipe the cell clean and apply a thin film of silicone oil to the surface. Place it in the cell holder and *close the cell cover*. Press **ENTER**.

The instrument display counts down from 60 to 0, and then takes a measurement. The display automatically increments to the next standard, the display shows 7500 NTU and the standard number 05 is displayed. Remove the sample cell from the instrument.

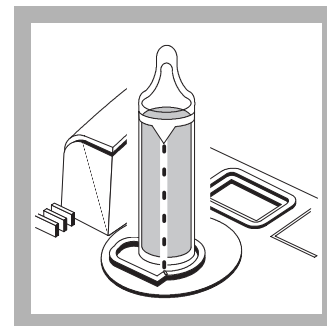

12. Handling the 7500-NTU Formazin ampule by the top, mix by gently inverting several times. Wipe the ampule clean and apply a thin film of silicone oil to the surface. Place it in the cell holder and close the cell cover. Ensure that the ampule orientation mark is aligned with the sample cell holder reference mark. Press **ENTER**.

The instrument display counts down from 60 to 0, and then takes a measurement. The displayed standard number will increment back to 00 and the previously measured value of the dilution water is displayed.



13. Press **CAL/Zero**. The instrument makes calculations based on the new calibration data, stores the new calibration and returns the instrument to the measurement mode.

Note: If power is lost during calibration, new calibration data is lost, and the old calibration remains in effect. To exit calibration without saving new values, press **UNITS/Exit**.

Note: If **ERR01** or **ERR02** appears in the display, an error occurred during calibration (refer to Table 5 on page 101). Clear the error message and proceed with measurements by pressing **ENTER**. However, Cal? annunciator will be on, indicating a questionable calibration. The Cal? annunciator is turned off only by recalibration, which removes erroneous data. Prepare new standards, and recalibrate the instrument. Make sure the Formazin standards are fresh and well mixed. Also check to ensure dilution water is < 0.5 NTU.

SECTION 3, continued

3.2.5 Handling StablCal® Sealed Vial Standards

Read these steps before handling the StablCal Standards.

Important Note: *Never shake or invert the < 0.1 NTU Standard. If the standard has been mixed or shaken, wait 15 minutes before using.*

If the standards have been used often (daily to weekly), begin with step 5.

If the standards have just arrived from the manufacturer or have been sitting undisturbed for longer than one week, begin with step 1.

1. Remove the < 0.1 NTU Standard from the plastic case and set it aside. Close the case lid.
2. Leave the remaining standards in the case and shake them for 2–3 minutes.
3. Let the standards stand undisturbed for 5 minutes.
4. Skip to Step 7, below.
5. Remove the < 0.1 NTU Standard from the plastic case and set it aside. Close the case lid.
6. Leave the remaining standards in the plastic case and invert the case 10 times.
7. Thoroughly clean, rinse, and dry the outside of the vials.
8. Immediately before using each standard, apply silicone oil (Cat. No. 1269-36) to the outside of the vial.
 - a. Apply a very thin bead of silicone oil from the top to bottom of the vial.
 - b. Spread the oil uniformly with the oiling cloth. Wipe off the excess so only a thin coat of oil remains. The vial should appear nearly dry with little or no visible oil.

Note: *Store the oiling cloth in a sealed plastic bag to keep it clean.*

9. Proceed with calibration.

SECTION 3, continued

3.2.6 Calibrating the Turbidimeter (Using StablCal® Sealed Vial Standards)

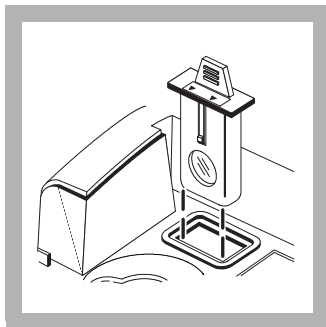

1. Insert the EPA filter module if measuring for EPA-reporting (2100N and 2100AN only).

Note: Clean the filter before performing a primary calibration, or at least every 3 months (which is the USEPA-recommended calibration frequency).

Note: Clean the filter with glass cleaner, lens cleaner, or isopropyl alcohol, and a cotton-tipped swab.



2. Press **CAL/Zero**.

The CAL mode annunciator lights, and the small green LED digits in the mode display flashes **00**. The NTU value of the dilution water used in the previous calibration is displayed.

Note: Ratio on and Ratio off calibration data are measured and recorded simultaneously.

Note: Calibration for EBC and NEPH units of measure is set automatically via the NTU calibration.

Note: Upon entering the Calibration Mode, Automatic Range, Signal Averaging On, Ratio on and NTU units are automatically selected. Upon completion of calibration, all operational modes are restored to precalibration settings.

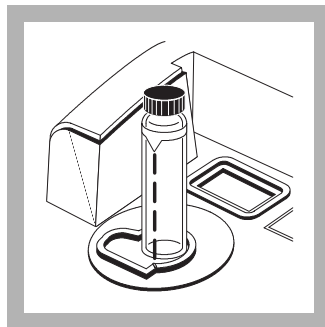

3. Select the StablCal vial labeled < 0.1 NTU. Wipe the cell clean and apply a thin film of silicone oil to its surface. Place it in the cell holder and close the cell cover. Press **ENTER**.

The instrument display counts down from **60** to **0**, and then takes a measurement. The instrument automatically increments to the next standard, the display shows 20.00 NTU, and the standard number **01** is shown in the mode display. Remove the < 0.1 NTU vial from the cell holder.

Note: Install all StablCal vials with the orientation mark aligned with the cell holder reference mark.

Note: To exit the calibration procedure at any time without changing any stored value, press **UNITS/Exit**.

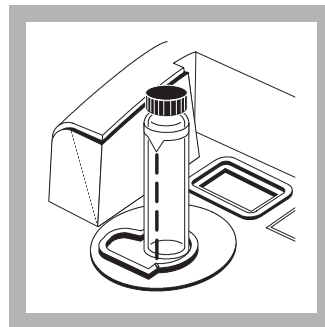

4. Select the StablCal vial labeled 20.00 NTU. Wipe the vial clean and apply a thin film of silicone oil to its surface. Place it in the cell holder and close the cell cover. Press **ENTER**.

Wait for the instrument to count down as before and display the next standard. Remove the vial from the cell holder.

SECTION 3, continued

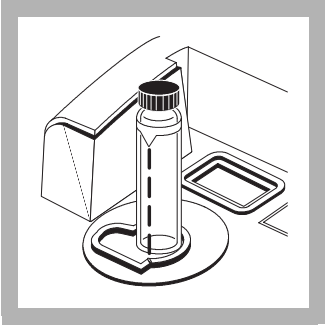

5. Select the StablCal vial labeled 200.0 NTU. Wipe the vial clean and apply a thin film of silicone oil to its surface. Place it in the cell holder and close the cell cover. Press **ENTER**.

Wait for the instrument to count down as before and display the next standard. Remove the vial from the cell holder.

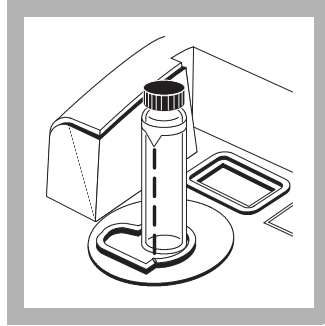

6. Select the StablCal vial labeled 1000 NTU. Wipe the vial clean and apply a thin film of silicone oil to its surface. Place it in the cell holder and close the cell cover. Press **ENTER**.

Wait for the instrument to count down as before and display the next standard. Remove the vial from the cell holder.

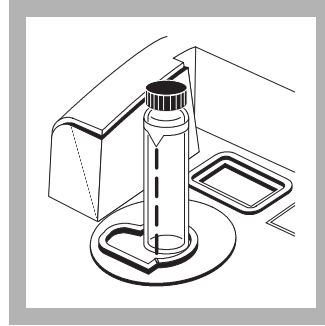

7. Select the StablCal vial labeled 4000 NTU. Wipe the vial clean and apply a thin film of silicone oil to its surface. Place it in the cell holder and close the cell cover. Press **ENTER**.

Wait for the instrument to count down as before and display the next standard. Remove the vial from the cell holder.

2100AN and **2100AN IS** instruments, complete step 8.

2100N and **2100N IS** instruments, skip to step 9.

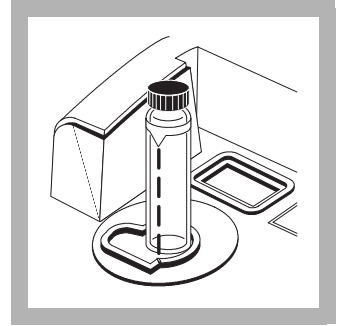

2100 AN and **2100 AN IS** instruments only:

8. Select the StablCal vial labeled 7500 NTU. Wipe the vial clean and apply a thin film of silicone oil to its surface. Place it in the cell holder and close the cell cover. Press **ENTER**.



9. Press **CAL/Zero**. The instrument makes calculations based on the new calibration data, stores the new calibration and returns to measurement mode.

Note: If power is lost during calibration, new calibration data is lost, and the previous calibration remains in effect. To exit the calibration without saving new values, press **UNITS/Exit**.

Note: If **ERR01** or **ERR02** appears in the display, an error occurred during calibration. Clear the error message and proceed with measurements by pressing **ENTER**. The **Cal?** annunciator will be on, indicating a questionable calibration. Turn the **Cal?** annunciator off by recalibrating the instrument to remove erroneous data.

3.2.6.1 Reviewing Calibration Data

To review calibration data currently in effect, press the **CAL/Zero** key, and then use the up arrow key to scroll through the standards. Pressing the **PRINT** key prints all of the calibration data in effect. Press the **UNITS/Exit** key to return to the operating mode. The stored calibration data is not affected.

SECTION 3, continued

3.2.7 Formulating Formazin Stock Solution

WARNING

To familiarize yourself with handling precautions, dangers and emergency procedures, always review the Material Safety Data Sheets prior to handling containers, reservoirs, and delivery systems that contain chemical reagents and standards. Protective eye wear always is recommended when contact with chemicals is possible.

ATTENTION

Pour se familiariser avec les précautions à prendre lors de la manipulation, les dangers et les procédures d'urgence, toujours lire les Fiches de Données de Sécurité avant de manipuler les récipients, les réservoirs et les systèmes de distribution contenant les réactifs chimiques et les solutions étalons. Il est toujours recommandé de porter des lunettes de protection lorsqu'un contact avec les produits chimiques est possible.

ADVERTENCIA

Para familiarizarse con las precauciones de manipulación, los peligros y los procedimientos de emergencia, siempre estudie las Hojas de Datos de Seguridad de los Materiales antes de manipular recipientes, depósitos y sistemas de entrega que contengan reactivos y patrones químicos. Siempre se recomienda el uso de protectores oculares cuando sea posible el contacto con productos químicos.

WARNHINWEIS

Es wird dringend empfohlen, die Sicherheitsdatenblätter vor der Handhabung von Behältern, Tanks und Zufuhrsystemen, die chemische Reagenzien und Standardsubstanzen enthalten, aufmerksam durchzulesen, damit Sie sich mit den beim Umgang mit diesen Chemikalien notwendigen Vorsichtsmaßnahmen, Risiken und Notfallschutzmaßnahmen vertraut machen. Es wird empfohlen, in allen Situationen, in denen mit einem Kontakt von Chemikalien zu rechnen ist, eine Schutzbrille zu tragen.

AVISO

Para familiarizarse com as precauções de manipulação, riscos e procedimentos de emergência, examine sempre o Folheto de Dados de Segurança antes de manipular os recipientes, tanques e sistemas de distribuição que contenham reagentes químicos e outros elementos padronizados. Se recomenda sempre o uso de protetores para olhos, quando possa acontecer contato com os produtos químicos.

Note: *Preparing Formazin from raw materials is not recommended. Preparation is temperature and technique sensitive. Use prepared 4000 NTU Formazin stock solution to avoid handling raw materials and for the best instrument performance and analytical standard accuracy.*

A 4000-NTU Formazin stock solution can be synthesized for making the calibration standard dilutions in place of using the prepared stock solution. Proceed as follows:

1. Dissolve 5.000 grams of reagent grade hydrazine sulfate ((NH₂)₂-H₂SO₄ Cat. No. 742-26) in approximately 400 mL of demineralized water.
2. Dissolve 50.000 grams of hexamethylenetetramine (Cat. No. 1878-34) in approximately 400 mL of demineralized water.
3. Quantitatively, pour the two solutions into a 1-liter volumetric flask, and dilute to volume with demineralized water. Mix well.
4. Allow the solution to stand for 24 hours at 25 ± 3 °C (77 ± 5 °F). The suspension develops during this time.

3.3 Special Research Applications

Special features and operations have been designed into the 2100AN Turbidimeter for special research applications. Refer to *SECTION 10* on page 91 for more information about application specific measurements, use of cell adapters, and interchangeable filter modules.

Independent detector output selection and monitoring also is possible. For example, if the back scattered light is needed to characterize a sample, the information is accessed easily. Refer to *Section 12.3.1* on page 102 for the instrument diagnostic code number needed for a specific method development.

3.3.1 Ignoring Dilution Water

The turbidity of the dilution water can be ignored by pressing right arrow rather than measuring the dilution water for the standard 00. The display shows ----. Press the up arrow to advance to the next standard. Ignoring the dilution water is not recommended for most applications because it may result in significant errors for measurements below 100 NTU. Use it only in situations where you know your dilution water is particle free.

3.3.2 Editing Calibration Data Points

Note: *The calibration is based on a first order linear equation consisting of up to four independent variables. Unpredictable results may occur if standards other than the recommended calibration points are used. The factory suggested calibration points are those determined by Hach Company chemists and engineers to provide the best calibration accuracy. Using Formazin standards other than those specified in Section 3.2.3 on page 41 may result in less accurate calibrations.*

When using Formazin standard dilutions other than the recommended 20-, 200-, 1000-, 4000- and 7500-NTU standards during calibration, edit these data points as they occur in the display in the calibration procedure to agree with the actual turbidity of the substituted standards.

For example, if during the calibration procedure a 25-NTU standard is placed in the instrument instead of the 20-NTU standard, the 20.00 in the display is edited to show the value of the new standard before the **ENTER** key is pressed to initiate the measurement. Pressing the right arrow key accesses the editing mode causing the decimal point to flash. Use the right arrow key to move the decimal point to the appropriate location. Pressing **ENTER** accepts the new decimal location and causes the 2 to flash. Because the 2 is correct as is, press the right arrow again to ready the second digit for editing. The up arrow increments the flashing digit to read 5 for the corrected display of 25.00. Now, when **ENTER** is pressed, the display counts down from 60 to 0 as the measurement is made and corrected to compensate for the turbidity of the dilution water. The instrument automatically increments to the next standard and the Mode display (green LED) shows 02. Continue with the calibration, editing values any other substituted standards.

SECTION 3, continued

3.3.3 Preparing Formazin Dilutions - User Selected

Hach Company recommends using 20, 200, 1000, 4000 and 7500-NTU formazin standards for calibrating the 2100AN Turbidimeter. Other dilutions can be prepared and used, but if problems occur when using these alternative solutions, use the dilutions specified in *Section 3.2.3* on page 41.

Prepare Formazin dilutions from well-mixed, 4000-NTU stock solution as specified in section *Section 3.2.3* on page 41 and dilution water as specified in section *Section 3.2.2* on page 41.

Prepare Formazin dilutions to span the entire range of the instrument. Four standards are required. The following are suggested:

- a. one in the range of 10 to 30 NTU
- b. one in the range of 180 to 220 NTU
- c. one in the range of 900 to 1,100 NTU
- d. one of 4000 NTU.

Standards must have a difference of at least 60 NTU. In addition, make a blank measurement using the same dilution water used in making the Formazin dilutions, and entered as the 00 calibration point.

Prepare standard solutions immediately before use, and discard the standards when calibration is complete.

3.3.4 Calibrating the 2100AN (user selected standards)

Instrument calibration is accomplished as described in *Section 3.2.4* on page 43 with two exceptions:

1. Standards are values other than those used in *steps 6, 9, 10, 11 and 12*.
2. Before pressing **ENTER** to measure each standard, edit the displayed value to agree with the actual turbidity of the standard. This is done by using first the right arrow to get into the editing mode and then using the right, up and down arrow keys to edit the number.

Note: For best accuracy, use the same sample cell or four matched sample cells for all measurements during calibration. Abort the calibration procedure at any time without changing any stored value by pressing the **UNITS/Exit** key.

4.1  Air Purge Connection

An air purge system is provided to purge the optical compartment with dry air to prevent condensation on the outside of the sample cell when measuring cold samples. This system is particularly useful when using the Flow-Thru Cell assembly.

Note: Do not exceed 138 kPa (20 psig).

Dry nitrogen or instrument grade air (ANSI MC 11.1, 1975) up to 138 kPa (20 psig) can be used to air purge the optical housing compartment. The recommended air consumption rate is between 3 and 10 SCFH (standard cubic feet/hour). The connection is made at the Air Purge fitting on the rear panel.

When the sample temperature is expected to be near or below 2 °C (35 °F), use a desiccant dryer and particle filter to assure the dew point of the air purge is below the sample temperature. The air dryer contains silica gel desiccant that turns pink when exhausted. Life expectancy of the desiccant depends on the moisture content of the air.

If only shop air is available, use a coalescing filter with automatic drain in conjunction with a dryer and particle filter to achieve instrument quality air. Life expectancy of the coalescing filter should exceed 2000 hours. Change the particle filter at the same time as the air dryer. *Figure 7* illustrates methods of connecting the two types of air supply to the instrument. The dryer and filter are not necessary if dry nitrogen is used for the air purge.

Figure 7 Air Purge Connections

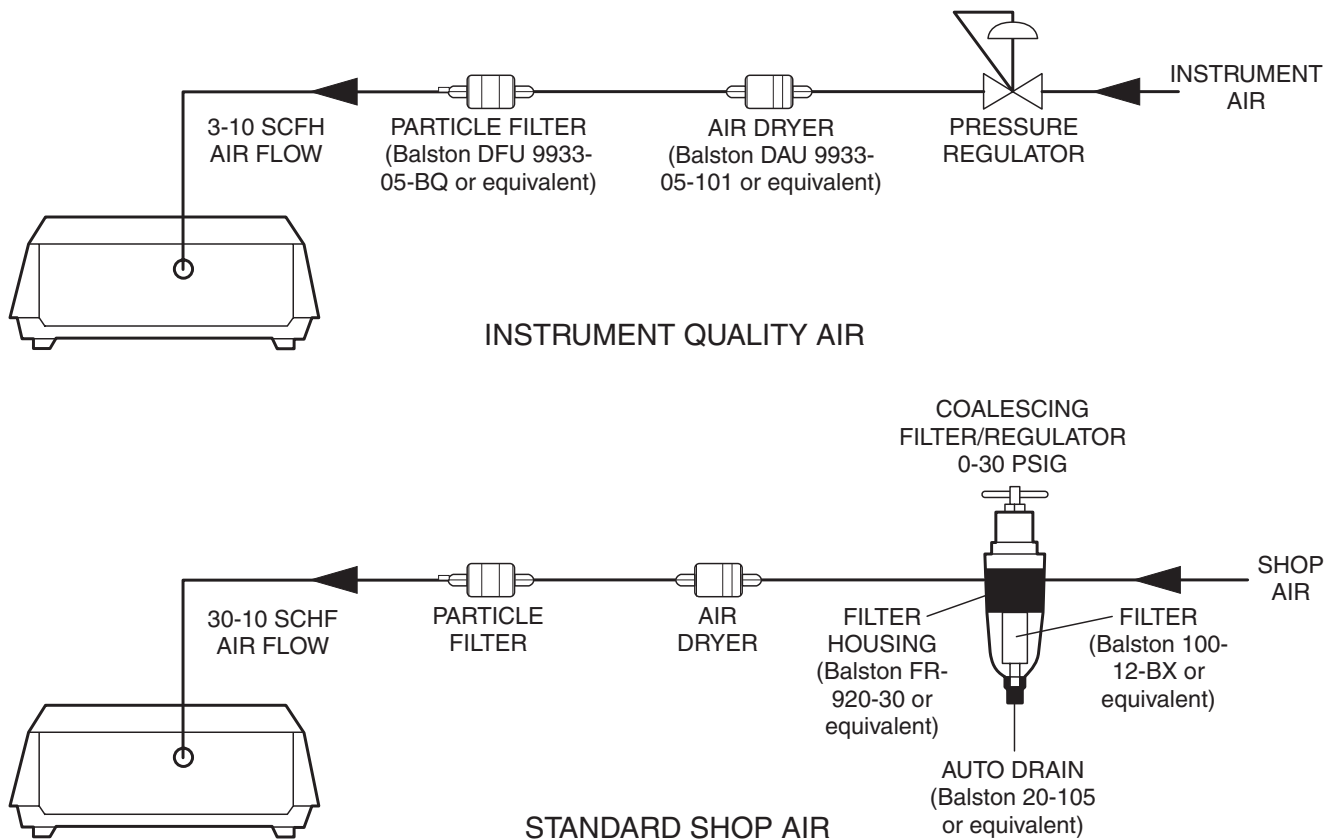

5.1 Description

Three optional Flow-Cell kits are available for the 2100AN Laboratory Turbidimeter. Two kits exist for low pressure applications [< 34 kPa (5psig)] and one kit for high pressure applications [< 414 kPa (60 psig)]

Flow-Cell advantages:

- Increases speed of measurement
- Provides a single cell for all measurements (thus assuring a constant optical path)
- Eliminates the need for matched cells
- Minimizes the amount of glassware that must be purchased, stored and cleaned

A constant optical path is the most important benefit of a Flow Cell. Variability, inherent flaws and scratches in sample-cell glass can cause significant errors in low-level optical measurements such as turbidity, color, transmittance and absorbance. Hach recommends using a Flow-Cell Assembly for low-level turbidity measurements. A Flow Cell is required to achieve the published accuracy and reproducibility specifications in color, absorbance or transmittance measurement modes.

WARNING

Do not use the Hach Flow Cells with flammable samples or those containing hydrocarbons, solvents, concentrated acids or concentrated bases that may attack wetted parts of the cells. Conduct tests prior to use of Flow Cells if sample compatibility is questionable.

ATTENTION

Ne pas utiliser les cuves à circulation Hach avec des échantillons inflammables ou ceux contenant des hydrocarbures, solvants, acides concentrés ou bases concentrées qui peuvent attaquer les parties au contact du liquide. Effectuer des essais avant l'utilisation des cuves à circulation si la compatibilité de l'échantillon est douteuse.

ADVERTENCIA

No use las Células de Flujo Flow Cells de Hach con muestras inflamables o que contengan hidocarburos, soventes, ácidos concentrados o bases concentradas que puedan atacar las partes mojables de la célula. Experimente antes de usar las Células de Flujo, si existe duda sobre la compatibilidad de la muestra

WARNHINWEIS

Durchflußküvetten von Hach dürfen nicht in Verbindung mit brennbaren Proben oder Proben, die Kohlenwasserstoffe, Lösemittel, konzentrierte Säuren oder konzentrierte Basen, die die benetzten Teile der Küvetten angreifen können, verwendet werden. Wenn die Verträglichkeit fraglich ist, sollten vor der Verwendung der Durchflußküvetten Tests durchgeführt werden.

AVISO

Não se deverá usar Celas de Fluxo hach con amostras inflamáveis ou aquelas que contêm hidrocarbonetos, solventes, ácidos concentrados ou bases concentradas que podem atacar as partes molhadas das celas. Realize os testes antes do uso das Celas de Fluxo se é questionável a compatibilidade das amostras.

SECTION 5, continued

5.2 Flow-Cell Kits (Low Pressure)

The Low Pressure Flow-Cell systems (manual or automated kits) use an innovative sample cell design* with a baffled inlet and dual outlets that minimize accumulation of entrapped air bubbles and heavy solid particles in the cell (see *Figure 8*). The glass cell is threaded on both ends to accommodate plastic end caps. The cell has an approximate volume of 22 mL when assembled. The parts disassemble easily for thorough cleaning.

Sample is introduced into the top of the cell (see *Figure 9*). A baffle deflects the incoming sample to the side wall of the cell minimizing turbulence in the light path.

Sample is discharged from top and bottom outlets. The top outlet collects and expels air bubbles and particles that tend to float. The conical-shaped bottom outlet collects settleable solids; water discharged from the bottom outlet carries the settled solids out of the cell. This novel, dual-outlet design eliminates dead volume in the cell to provide rapid, thorough flushing of the cell from one sample to the next.

Figure 8 Low Pressure Flow Cell Assembly

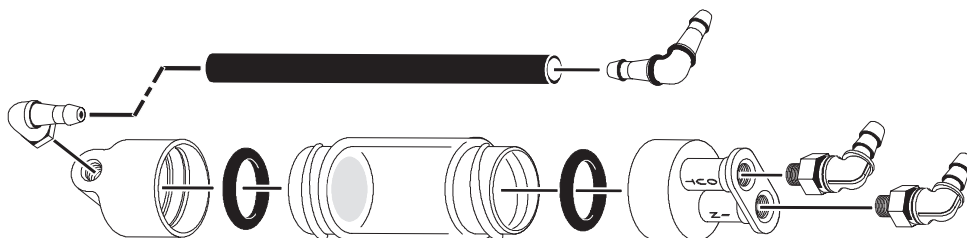

* U.S. patent D358,448; other patents pending.

SECTION 5, continued

Figure 9 Manual Low Pressure Flow Cell

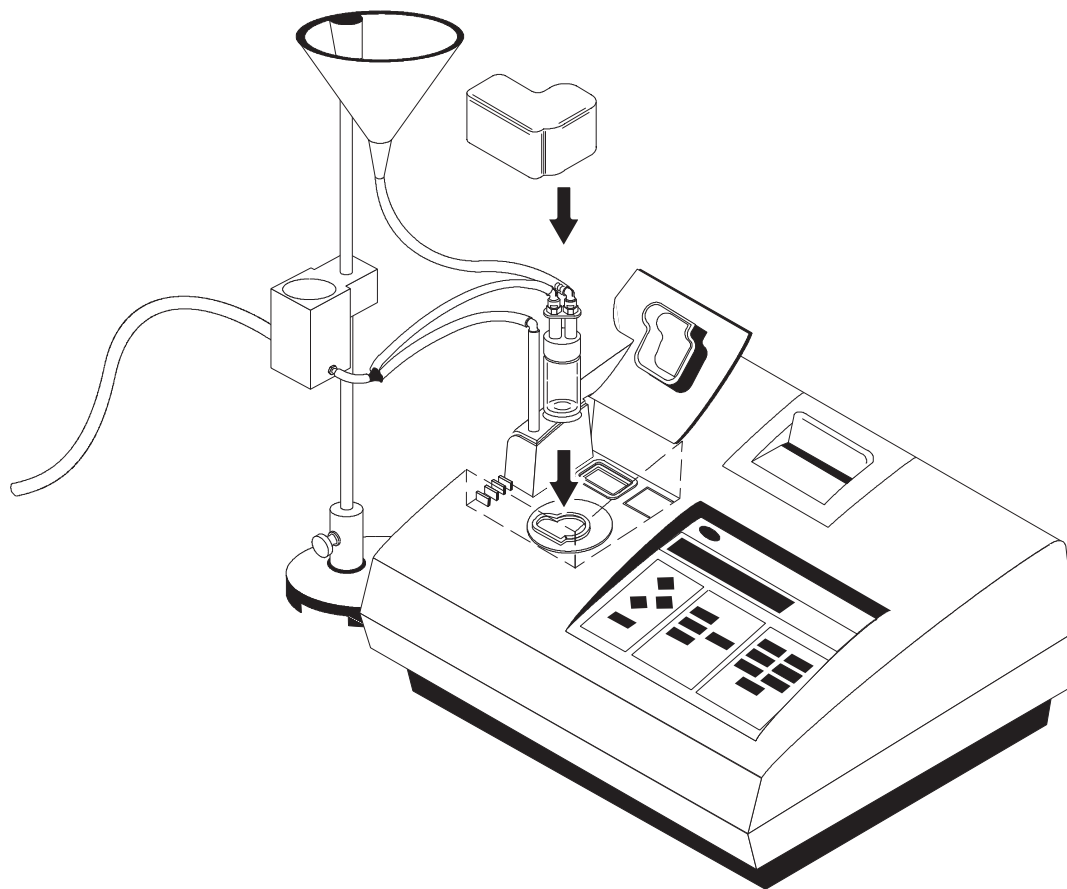

5.2.1 Manual Flow-Cell Kit (Low Pressure)

The Manual Flow-Cell Kit (Cat. No. 47449-00) is for low pressure [<34 kPa (5 psig)] applications (see Figure 9).

The kit consists of a Flow-Cell Stand Assembly, a Flow-Cell Inlet Reservoir with a capacity of 350 mL, a Reservoir Cover, a Collection Drain Assembly, the Flow-Cell Assembly, interconnecting tubing, and a Flow-Cell Light Shield.

CAUTION

The manual and automated, Low Pressure Flow Cell setup is designed for low pressure use only [<34 kPa (5 psig)].

PRUDENCE

La cuve à circulation basse pression, manuelle ou automatisée, est conçue pour utilisation sous faible pression uniquement [$<0,34$ bar (34 kPa - 5 psig)].

PRECAUCION

La Célula de Flujo de faja presión, tanto manual como automática, ha sido diseñada para baja presión solamente [34 kPa (5 psig - lbs/pulg.² sobre la presión atmosférica)].

VORSICHT

Die manuelle und die automatisierte Niederdruck-Durchflußküvette ist nur für Niederdruckanwendungen geeignet [<34 kPa (ca. 0,3 bar)].

PRECAUÇÃO

A Cella de Fluxo à baixa pressão manual e automatizada é projectada apenas para uso à baixa pressão [<34 kPa (5 libras/polegada quadrada manômetro)].

SECTION 5, continued

5.2.1.1 Assembling the Support Stand

1. Verify the sample compartment is empty, and turn the instrument off.
2. Turn the instrument on its top (place it on a soft cloth to protect the instrument from marring), and install the base plate of the stand as illustrated in *Figure 10*. DO NOT OVERTIGHTEN THE SCREWS.
3. Place the instrument right side up.
4. Install the Flow-Cell Inlet Reservoir on to the support rod.
5. Slide the Collection Drain Assembly on to the support rod.
6. Place the instrument right-side up, and install the support rod into the base. Tighten the thumb screw to secure the rod.

Figure 10 Base Plate Installation

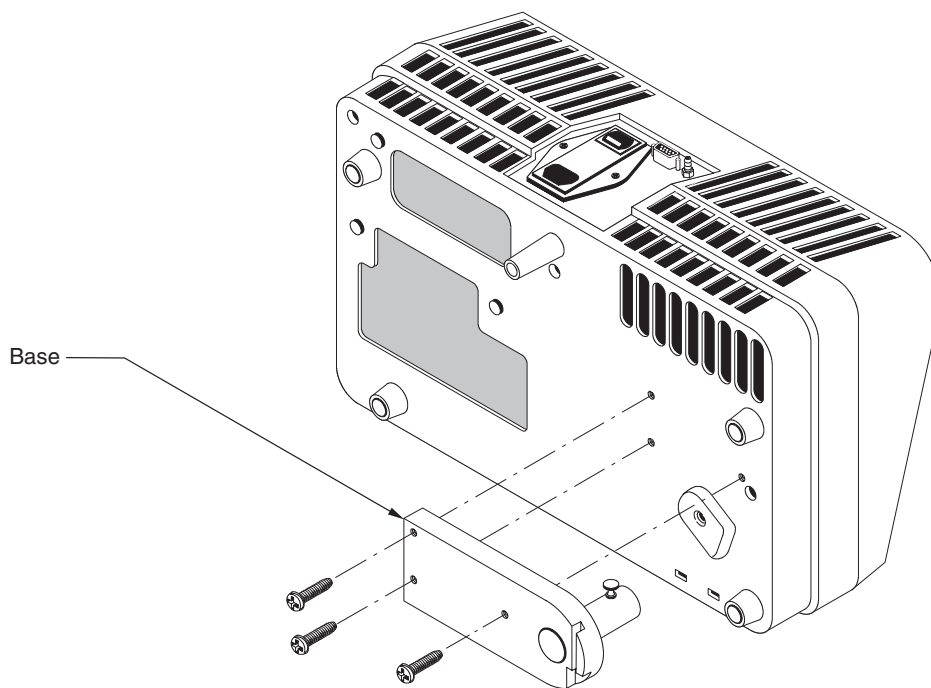

SECTION 5, continued

5.2.1.2 Assembling the Flow Cell

Verify the O-rings have been installed in the top and bottom end caps; then screw the caps on to the glass sample cell. Tighten the caps enough to ensure a water-tight seal, but do not over tighten.

5.2.1.3 Connecting Inlet and Outlet Tubing

Note: Use the tubing supplied with the kit (or its equivalent). Tubing lengths are approximate. Avoid using excess tubing because it causes air locking, and delays measurement response time.

1. Cut a 53-cm (21") piece of clear, $1/8$ " I.D. Tygon tubing, and install it between the inlet reservoir and cell inlet.
2. Cut two 23-cm (9") pieces of clear, $1/8$ " I.D. Tygon tubing, and install them between the top and bottom Flow Cell drain fittings and the "Y" connector.
3. Cut a 2.5-cm (1") piece of clear, $1/8$ " I.D. Tygon tubing, and install it between the "Y" connector and the Collection Drain Assembly.
4. Cut a 50-cm (20") length of clear, $3/8$ " I.D. Tygon tubing for the drain line. Connect one end to the drain barb on the Collection Drain Assembly, and run the other end to a suitable drain.

The discharge end of the drain tube must be unrestricted and lower than the instrument for proper drain flow and prevention of air locking. Locate the instrument as close to the drain as is practical using the shortest length of drain tubing possible.

The kit is supplied with 152 cm (5') of $3/8$ " tubing. The system will not drain properly if this length is exceeded. If the entire length is used, the end of the drain tubing must discharge at a point at least 46 cm (15") below the center line of the instrument to ensure proper flow.

5.2.1.4 Using the Manual Flow-Cell Kit

Note: Assemble the Flow Cell, tubing and stand. Fill the system with water to ensure all connections are water tight before inserting the Flow Cell into the sample compartment of the instrument. Inspect the system for leaks. Also, make sure the cell is clean, and no air bubbles are present. Air bubbles tend to collect in areas that are not cleaned thoroughly.

Thoroughly clean the flow cell (refer to *Section 5.2.5* on page 69). Apply a thin coat of silicone oil to the outside of the flow cell.

Install the Flow Cell in the sample compartment and press the inlet and outlet tubes into the slots provided on the instrument's top enclosure (see *Figure 9*). Cover the cell with the Flow-Cell Light Cover.

The Flow-Cell Light Cover must be installed at all times when the Flow Cell is in use. The instrument's cell cover does not close when the Flow Cell is installed.

Flow rate through the Flow Cell is controlled by adjusting the height of the Collection Drain Assembly on the Support Rod. Position the bottom of the Collection Drain Assembly a minimum of 7.5 cm (3") above the support stand base. Raise the Collection Drain Assembly on the Support Rod to decrease the rate of flow. Lower the Collection Drain Assembly until it rests against the support base to purge the Flow Cell of sample.

Carefully add sample to the Inlet Reservoir to minimize entrapment of air bubbles in the sample. Air bubbles create a false positive interference in turbidity measurement. Always slowly pour sample down the inside edge of the reservoir.

SECTION 5, continued

5.2.2 Automated Flow-Cell Kit (Low Pressure)

The Automated Low Pressure Flow-Cell Kit (Cat. No. 47450-00, 115 Vac or 47450-02, 230 Vac), uses a Flow Valve Module for control of sample flow (see *Figure 11*). The kit contains a remote control cable used with the Model 2100AN Turbidimeter for automated operation. Refer to *Section 5.2.1.1* and *Section 5.2.1.2* for assembly instructions. Omit step 5 in *Section 5.2.1.1*; the Collection Drain Assembly is not provided with the Automated Flow-Cell Kit.

Figure 11 Automated Low Pressure Flow Cell

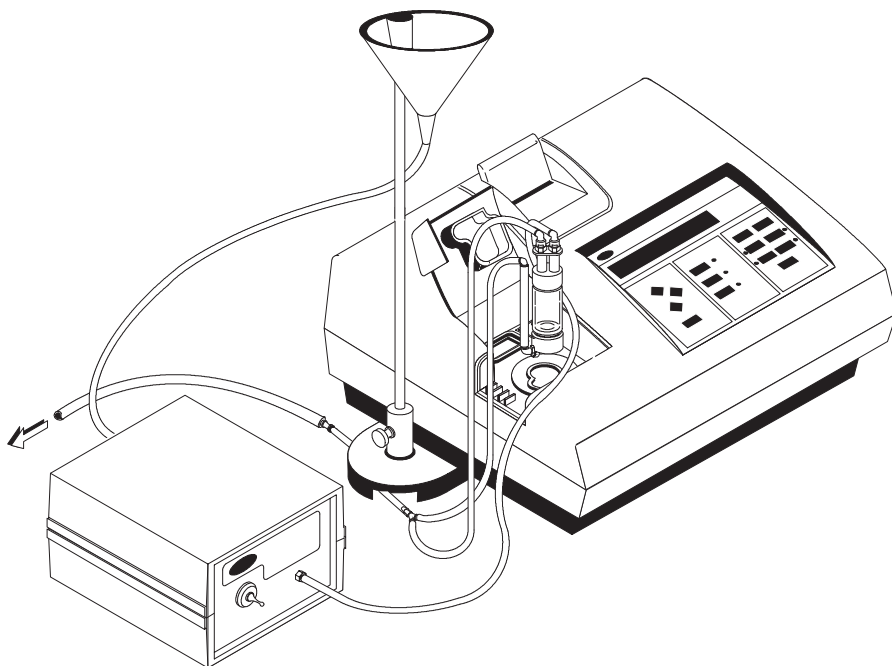

5.2.2.1 Connecting Inlet and Outlet Tubing

1. Cut a 53-cm (21") piece of clear, $\frac{1}{8}$ " I.D. Tygon tubing. Install it between the Flow-Cell Inlet Reservoir and Flow Valve Module inlet.

Note: Use the tubing supplied with the kit (or its equivalent). Tubing lengths are approximate. Avoid using excess tubing because it causes air locking, and delays measurement response time.

2. Cut a 31-cm (12") piece of clear, $\frac{1}{8}$ " I.D. Tygon tubing. Install it between the Flow Valve Module outlet and the Flow-Cell inlet.
3. Cut two 25-cm (10") pieces of clear, $\frac{1}{8}$ " I.D. Tygon tubing. Install them between the top and bottom Flow Cell drain fittings and the "Y" connector.
4. Cut a 11-cm (4") piece of clear, $\frac{1}{8}$ " I.D. Tygon tubing. Connect one end to the remaining "Y" connector. Pass the tubing under the support stand base as illustrated in *Figure 11*. Install the $\frac{1}{8}$ " x $\frac{1}{4}$ " reducer on the other end of the tubing.
5. Cut a 50-cm (20") piece of clear, $\frac{1}{4}$ " I.D. Tygon tubing for the drain line. Connect one end to the $\frac{1}{8}$ " x $\frac{1}{4}$ " reducer, and run the other end to a suitable drain.

SECTION 5, continued

The discharge end of the drain tube must be unrestricted and lower than the instrument to prevent air locking and ensure proper drain flow. Locate the instrument as close to the drain as is practical using the shortest length of drain tubing possible.

The kit is supplied with 152 cm (5') of 1/4" tubing. The system will not drain properly if this length is exceeded. If the entire 152 cm is used, the end of the drain tubing must discharge at a point at least 46 cm (15") below the center line of the instrument to ensure proper flow.

6. Connect the power supply to the Power jack on the Flow Valve Module. Plug the power supply into an appropriate wall receptacle.
7. Connect the Remote jack on the back of the 2100AN Turbidimeter to the Remote jack on the back of the Flow Valve Module using the remote cable.

5.2.2.2 Using the Automated Flow-Cell Kit

Note: Assemble the Flow Cell, tubing and stand. Then, fill the system with water to ensure all connections are water tight before inserting the Flow Cell into the sample compartment of the instrument. Once filled, inspect the system for leaks. Also, make sure the cell is clean, and there are no air bubbles present. Air bubbles tend to collect in areas that are not cleaned thoroughly.

Thoroughly clean the Flow Cell (refer to *Section 5.2.5* on page 69), and then apply a thin coat of silicone oil to the outside of the cell (see *Section 2.3.2.1* on page 23). Install the Flow Cell in the sample compartment, and press the inlet and outlet tubes into the slots provided on the instrument's top enclosure (see *Figure 11*). Cover the cell with the Flow-Cell Light Cover.

The Flow-Cell Light Cover must be installed at all times when the Flow Cell is in use. The instrument's cell cover does not close when the Flow Cell is installed.

Manual flow through the Flow Cell is controlled by using the valve-control switch on the Flow Valve Module. The valve control is a three-position switch: *Continuous Open*, *Closed*, and *Momentary Open*. The valve is closed in the center (*Closed*) position. The valve remains open when the switch is in the up (*Continuous Open*) position until the switch is moved to the center (*Closed*) position. The down (*Momentary Open*) position must be pressed and held to open the valve; when released it automatically returns to the center (*Closed*) position.

Leave the control switch in the center (*Closed*) position for automated, remote control operation of the Flow Valve Module with the 2100AN Turbidimeter. *Static* or *Dynamic* measurement is selectable on the 2100AN Turbidimeter during automated operation; *fill time* and *measurement time* also are programmable.

Carefully add sample to the Inlet Reservoir to minimize entrapment of air bubbles in the sample. Air bubbles create a false positive interference in turbidity measurement. Always slowly pour sample down the inside edge of the reservoir.

5.2.2.3 Selecting Static or Dynamic Modes

The 2100AN Turbidimeter is programmable for making *static* (discrete sample volume) or *dynamic* (continuous flow) sample measurements during automatic operation. The flow valve opens for a programmed *fill time* when the *Static* mode is selected; the Flow Cell fills and purges the previous sample. The flow valve closes when the specified time period ends, trapping the last portion of sample flowing through the cell so that a discrete, non-flowing (*static*) sample volume is measured. When the measurement cycle is complete, the final reading in the instrument's display is held and automatically transmitted to the built-in printer (and/or through the RS232 output to an external printer or computer if connected).

SECTION 5, continued

In *Dynamic* mode, the flow valve remains open at the end of the programmed *fill time*. Measurement is made on the flowing (*dynamic*) sample stream as it moves through the Flow Cell.

5.2.2.4 Selecting FILL TIME

The *fill time* is the time interval that the Flow Valve remains open so that sample flows through the system before measurements are taken. *Fill time* is programmable from 0 seconds to 99 minutes and 99 seconds. A *fill time* setting of 0 seconds causes the instrument to begin measurement with no delay. Select the *fill time* duration to account for filling the system and also to thoroughly purge the system of all previous sample. The total volume of the Flow-Cell System (excluding the 350-mL Inlet Reservoir), from the discharge of the Inlet Reservoir to the outlet of the Flow-Cell, is approximately 30 mL. Flow rate through the system is approximately 250 mL/min.

Hach Company suggests a minimum volume of 120 mL (fill time = 30 seconds) to purge the system of previous sample. This volume purges the system approximately 4 times. A shorter *fill time* may be appropriate when making repeated measurements of the same sample.

When measuring several samples of varying turbidity, measure the samples in order of the cleanest (lowest turbidity) to the dirtiest (highest turbidity) to minimize carry-over from one sample to the next.

5.2.2.5 Selecting MEASUREMENT TIME

Measurement time is the time interval the instrument actively measures the sample turbidity. A measurement is completed approximately once per second, and the display is updated.

Measurement time is programmable from 0 to 99 minutes and 99 seconds. The last displayed value is held in the display and the results of measurement are automatically transmitted to the built-in printer (and/or through the RS232 output to an external printer or computer if connected) at the end of the programmed *measurement time*. The instrument continues to hold the last value until the **FLOW** key is pressed to exit the **FLOW** mode, or the **ENTER** key is pressed to repeat the measurement portion of the cycle without repeating the *fill time*.

Note: A minimum measurement time of 15 seconds is required.

Selection of a 0 *measurement time* provides continuous measurement that may be desirable when operating in the *dynamic* measurement mode; the instrument continues sample measurement until the **FLOW** key is pressed to exit the Flow mode. Selection of a 0 *measurement time* for *static* measurements is of limited value when using the *static* measurement mode because particles in the sample may settle over time. Therefore, the resulting measurements may not be representative of original sample.

5.2.2.6 Using STATIC Measurement Mode

Note: Check to ensure the proper wavelength filter module is installed before beginning measurement (see SECTION 10 on page 91).

In the *static* mode the Flow Valve opens, the cell fills, sample continues to flow for the programmed *fill time interval*, and then the Flow Valve closes. The turbidimeter makes measurements during the programmed *measurement time*. The final reading is held in the display, and the result of the measurement is transmitted to the built-in printer (and/or through the RS232 output to an external printer or computer if connected).

SECTION 5, continued

Note: Measurements in the Flow mode of operation can be made with Signal Averaging and Ratio modes on or off. Signal Averaging and Ratio modes should be on for most measurements. Signal Averaging and Ratio on or off must be selected prior to entering the Flow mode.

1. Select the desired settings for Signal Averaging on or off and Ratio on or off.
2. Select the printer and print interval desired (see *Section 6.3 Printer*).
3. Press the **FLOW** key. The Flow annunciator lights and the display prompts either **STAT?** (for static measurement) or **DYN?** (for dynamic measurement).
4. Use the up or down arrow key to select **STAT**, then press **ENTER**.
5. Set the *fill time*. The display shows **MM-SS FIL** (or an actual *fill time* if one has been programmed previously).

Press **ENTER** to accept the displayed setting. Or, use the right arrow key to select the digit to edit, then the up or down arrow keys to edit the *fill time*. Press **ENTER** to accept the new time.

6. Set the *measurement time*. The display shows **MM-SS MEA** (or an actual *measurement time* if one has been programmed previously). Press **ENTER** to accept the displayed setting. Or use the right arrow key to select the digit to edit, then the up or down arrow keys to edit the *measurement time*. Press **ENTER** to accept the new time. After **ENTER** is pressed, the Flow Valve opens and remains open for the programmed *fill time* interval. Then the Flow Valve closes, and the turbidimeter completes sample measurements for the programmed *measurement time*.
7. The result of the measurement is locked in the display, and transmitted to the built-in printer (and/or through the RS232 output to an external printer or computer if connected) at the end of the *measurement time*. The **FLOW** annunciator flashes.

Note: The result of measurement remains locked in the display until the **FLOW** key is pressed to exit the **FLOW** mode or the **ENTER** key is pressed to repeat the programmed measurement cycle (programmed *fill time* is not repeated).

8. Press **ENTER** to repeat the measurement without the *fill time* delay. The instrument repeats sample measurement. The Flow Valve is open during the programmed measurement time. The result of measurement is locked in the display, and transmitted to an active printer or computer.

Note: To repeat the cycle (including the programmed *fill time*), press the **FLOW** key to exit the Flow mode. Press the **FLOW** key again to reenter the Flow mode, and press the **ENTER** key to accept previous settings for *fill time* and *measurement time*.

9. Press **FLOW** to exit the Flow mode. The Flow annunciator goes out, and the instrument display becomes active again.
10. To purge the Flow-Cell system of sample, press and hold the valve control switch on the Flow Valve Module in the *Momentary Open* position until the system drains.

Note: During short periods of time when the Flow-Cell system is not in use, flush the system with distilled or deionized water, and leave it full of the flush water. If the system is not used for a long period of time, disassemble and clean thoroughly.

SECTION 5, continued

5.2.2.7 Using Dynamic Measurement Mode

Note: Check to ensure the proper wavelength filter module is installed before beginning measurement.

Note: Measurements in the Flow mode of operation can be made with Signal Averaging and Ratio modes on or off. Signal Averaging and Ratio should be on for most measurements.

In the *dynamic* mode the Flow Valve opens, the cell fills and sample continues to flow for the programmed *fill time* interval. The Flow Valve remains open, and sample continues to flow for the programmed *measurement time* interval. Measurements are completed on the flowing sample. At the end of the programmed *measurement time*, the Flow Valve closes, and the final reading is held in the display. The result of the measurement is transmitted to the built-in printer (and/or through the RS232 output to an external printer or computer if connected).

1. Select the desired settings for Signal Averaging on or off and Ratio on or off.
2. Select the printer and print interval desired.

Note: Set the printer to print periodically when using the dynamic mode of operation in order to record the intermittent readings. For example, the print interval could be set to print every 30 seconds during a measured flow.

3. Press the **FLOW** key. The Flow annunciator lights and the display prompts either **STAT?** (for static measurement) or **DYN?** (for dynamic measurement).
4. Use the up or down arrow key to select **DYN**, then press **ENTER**.
5. Set the *fill time*. The display shows **MM-SS FIL** (or an actual *fill time* if one has been programmed previously). Press **ENTER** to accept the displayed setting. Or, use the right arrow key to select the digit to edit, then the up or down arrow keys to edit the *fill time*. Press **ENTER** to accept the new time.
6. Set the *measurement time*. The display shows **MM-SS MEA**. Press **ENTER** to accepted the displayed setting. Or, use the right arrow key to select the digit to edit, and then the up or down arrow keys to edit the *measurement time*. Press **ENTER** to accept the new time. After **ENTER** is pressed, the Flow Valve opens and remains open during the programmed *fill time* and *measurement time* intervals.
7. At the end of the *measurement time* the Flow Valve closes, the result of the measurement is held in the display and transmitted to the built-in printer (and/or through the RS232 output to an external printer or computer if connected). The Flow annunciator flashes.

Note: The result of the measurement remains in the display until the **FLOW** key is pressed to exit the Flow mode or the **ENTER** key is pressed to repeat the measurement.

8. Press **ENTER** to repeat the measurement without the *fill time* delay. The Flow Valve opens, and the instrument repeats the sample measurement for the programmed *measurement time*. Then, the Flow Valve closes, and the last measurement is locked in the display and transmitted to an active printer or computer.

Note: Notice that the Flow Valve opens and flow resumes. Ensure there is sufficient sample available if the measurement is repeated.

Note: To repeat the measurement cycle (including the programmed *fill time*), press the **FLOW** key to exit the Flow mode, and press the **FLOW** key to reenter the Flow mode. Press **ENTER** twice to accept the previously selected *fill time* and *measurement time*.

SECTION 5, continued

9. Press **FLOW** to exit the Flow mode. The Flow annunciator goes out, and the instrument display activates again.
10. To purge the Flow-Cell system of sample, press and hold the valve control switch on the Flow Valve Module in the *Momentary Open* position until the system drains.

Note: *During short periods of time when the Flow-Cell system is not in use, flush the system with distilled or deionized water, and leave it full of the flush water. If the system is not used for a long period of time, disassemble and clean thoroughly.*

5.2.3 Tips for Flow-Cell Kits (Low Pressure)

- Keep all parts of the system clean. Air bubbles form around areas that are not cleaned thoroughly.
- Hach Company suggests a minimum volume of 120 mL (fill time = 30 seconds) to purge the system of previous sample. This volume purges the system approximately four times. A shorter fill time may be appropriate when making repeated measurements of the same sample.
- If bubbles tend to collect in the Flow Cell, gently tap the cell on a soft surface to dislodge them.
- Periodically replace all tubing to ensure the system is clean.
- Do not attempt to use the Flow Cell for samples containing large particles that may clog the system.
- Install the reservoir cover when the system is not in use to prevent contamination of the system by airborne particles.
- Always carefully pour sample down the inside edge of the inlet reservoir to minimize agitation of the sample, which can entrain air bubbles.
- Do not use the systems for monitoring flammable solutions, solvents, strong acids or strong bases.
- Do not exceed the recommended maximum sample pressure of 34 kPa (5 psig).
- Fill the system with distilled or deionized water when it is not used for short periods of time (a few hours). This minimizes air locks and build up of residue on the components.

SECTION 5, continued

5.2.4 High Pressure Flow-Cell Kit

The High Pressure Flow-Cell Kit can be used for continuous measurement of a process stream, and accommodates up to 414 kPa (60 psig) (see *Figure 12*). It can operate continuously in temperatures up to 30 °C (86 °F), and intermittently in temperatures up to 40 °C (104 °F). All wetted parts are fabricated from materials approved by the United States Food and Drug Administration (FDA), and can be steam sterilized.

Prepare the High Pressure Flow Cell as follows:

Note: Hand-tighten the compression fitting nuts. Excessive force may damage the fitting or cap assembly.

1. Connect 1/4" O.D. tubing (of appropriate lengths for sample-in and sample-out connections) to the inlet and outlet fittings on the cap assembly as described in steps 1, 2 and 3 of *Figure 13*. The Flow-Cell cap fittings are compression fittings suitable for 1/4" O.D. polyethylene, metal, glass or clear vinyl tubing. Clear vinyl tubing requires an internal tube support. Step 4 of *Figure 13* describes the method for removing tubing from this type of compression fitting (shown in the cross-section drawing in *Figure 14*).

Figure 12 High Pressure Flow Cell

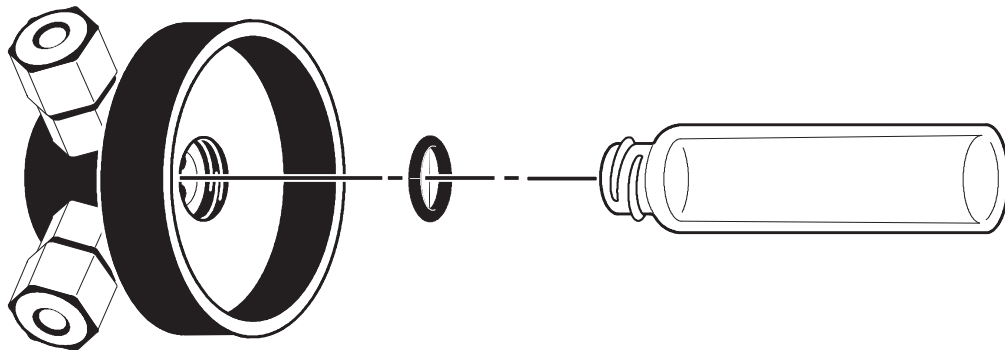
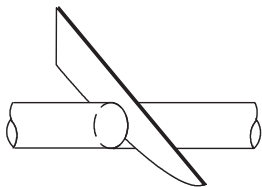
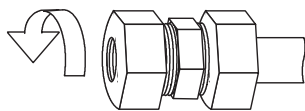

Figure 13 Compression Fitting Connection



Step 1
Cut the tube end at a slight angle for easy insertion. Debur metal or glass tubing to prevent O-ring damage and to promote ease of assembly



Step 2
Loosen the nut on the fitting until about three threads are visible. Moisten the end of the tubing with water or other suitable lubricant.

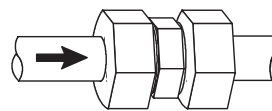

Step 3
Insert the tube into the fitting until the tube bottoms on the fitting shoulder. Hand-tighten the nut. Additional tightening is not necessary.

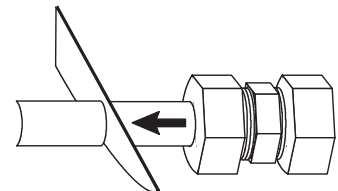

Step 4
Cut the tube off behind the nut to reuse the fitting internal parts. Pull the parts off the tube stub end backwards. Replace the parts in the fitting body. Assemble the nut, and insert the new tubing (as in Step 3).

SECTION 5, continued

Figure 15 illustrates a suggested hookup using a pressure regulator in the inlet line and a flow meter or flow control valve on the outlet line. The control valve is installed on the outlet side because it may introduce bubbles into the sample causing positive interference in the turbidity reading. This hookup also maintains sufficient pressure to minimize outgassing in a carbonated stream.

Figure 14 Compression Fitting

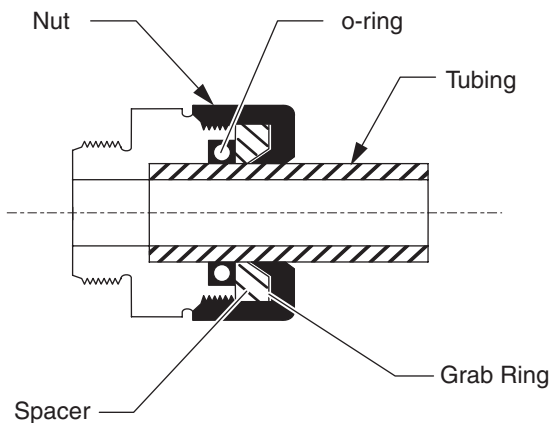
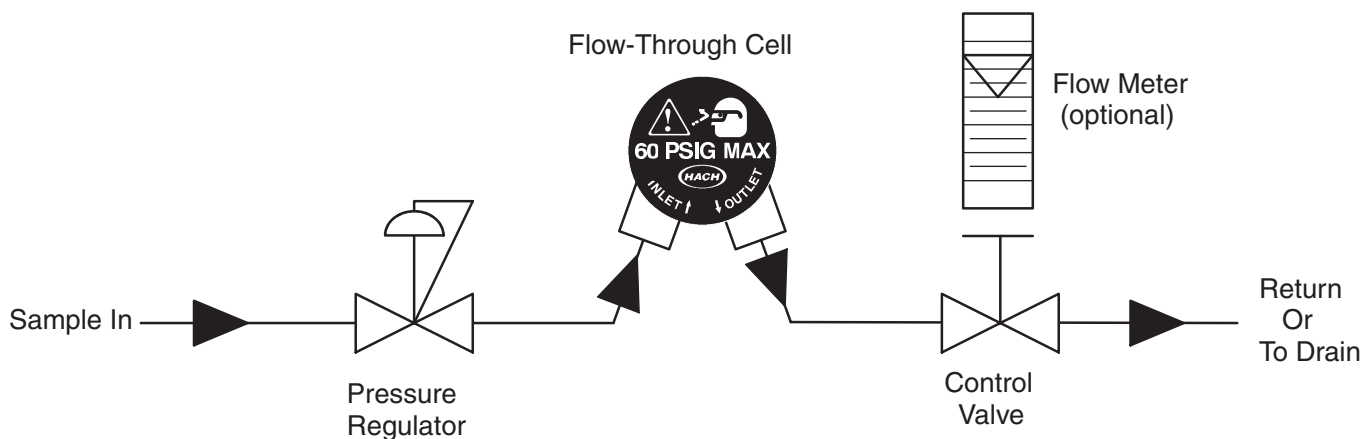

Figure 15 Suggested High Pressure Installation



SECTION 5, continued

CAUTION

Provide back-flow protection to prevent pressure surges from exceeding 60 psig in applications where sample is returned to a pressurized line.

PRUDENCE

Installer une protection antire-tour pour éviter les variations brusques de pression audessus de 4 bar (400 kPa, 60 psig) dans les applications où l'échantillon retourne dans une ligne sous pression.

PRECAUCION

Tome medidas para eliminar el reflujo para evitar golpes de presión que excedan 60 lbs/pulg. cuadrada en el manómetro (psig) en aplicaciones en las que la muestra retorna a una línea bajo presión.

VORSICHT

Es ist für einen Rücklaufschutz zu sorgen, um zu verhindern, daß Druckstöße bei Anwendungen, bei denen die Probe in eine unter Druck stehende Leitung zurückgeführt wird, 4,2 bar überschreiten.

PRECAUÇÃO

Deverseá fornecer proteção de contra-fluxo para impedir aumentos repentinos de pressão que excederem de 60 libras por polegada quadrada em aplicações em que a amostra regressar a um cano sob pressão.

2. Thoroughly clean the glass sample cell, and screw it into the cap assembly (see Figure 12 on page 66). Make sure the O-ring is in place in the cap assembly to ensure a good seal (hand tighten). Wipe the glass surface free of fingerprints and smudges. Apply a thin, even film of silicone oil to the outside surface.

WARNING

Use only glass sample cells that are screened "PRESSURE TESTED, 60 PSIG". Use of any other cells may result in injury to the operator and damage to the instrument. In the event of leakage or breakage, immediately depressurize the system and disconnect power.

ADVERTENCIA

Use solamente células de vidrio que estén clasificadas "PRESSURE TESTED, 60 PSIG". El empleo de cualquier otro tipo de célula puede resultar en lesiones al operador y daños al equipo. Si ocurrieran escapes o roturas, inmediatamente alivie la presión del sistema y desconecte la energía.

AVISO

Deverseá fornecer proteção de contrafluxo para impedir aumentos repentinos de pressão que excederem de 60 libras por polegada quadrada em aplicações em que a amostra regressar a um cano sob pressão.

ATTENTION

Utiliser seulement les cuves en verre marquées "PRESSURE TESTED, 60 PSIG" (éprouvée à la pression, 60 psig # 4 bar). L'utilisation de toute autre cuve présente des risques de blessures de l'opérateur et de dommages pour l'appareil. En cas de fuite ou de bris de cuve, dépressuriser immédiatement le système et débrancher l'alimentation électrique.

WARNHINWEIS

Es dürfen nur Glasküvetten benutzt werden, die bis 4,2 bar druckgeschützt sind. Die Verwendung anderer Küvetten kann zu Verletzungen des Benutzers oder zu Schäden am Gerät führen. Sollten Küvetten auslaufen oder zerbrechen, muß das System sofort entlüftet und die Stromzuführung unterbrochen werden.

3. Start sample flow through the system, and watch for leaks at the top of the sample cell. Adjust the pressure regulator to maintain pressure below 414 kPa (60 psig). Adjust the flow-control valve to a suitable flow rate below 500 mL/minute. Generally, low flow rates minimize signal noise caused by bubbles and particulate matter.

SECTION 5, continued

WARNING

Use eye protection and handle with extreme care when pressurizing the system with the Flow Cell out of the instrument. Do not hold the unit by the glass cell. Use a protective shield between the operator and the cell.

ADVERTENCIA

Use protección de los ojos y manipule con extrema precaución al iniciar la presión en el sistema mientras la célula de Flujo Continuo esté retirada del instrumento. No sostenga la unidad tomándola por la célula de vidrio. Interponga un escudo protector entre el operador y la célula.

PRECAUÇÃO

Usar proteção para os olhos e manusear com muito cuidado ao pressurizar o sistema com a cela Flow fora do instrumento. Não sustenha com a mão a unidade pela cela de vidro. Usar um protetor entre o usuário e a cela.

PRUDENCE

Porter des lunettes de protection et manipuler avec une extrême prudence lors de la pressurisation du système avec la cuve à circulation hors de l'appareil. Ne pas tenir l'ensemble par la cuve en verre. Utiliser un écran de protection entre l'opérateur et la cuve.

VORSICHT

Wenn das System unter Druck gesetzt wird, während sich die Durchflußküvette nicht im Gerät befindet, ist mit äußerster Vorsicht zu arbeiten; ein Augenschutz sollte getragen werden. Die Einheit darf nicht an der Glasküvette festgehalten werden. Zwischen Küvette und Benutzer sollte ein Schutzschild aufgestellt werden.

4. Insert the Flow Cell into the instrument cell holder.

Note: *The High Pressure Flow-Cell Assembly does not require the use of a light shield. The system is designed to operate with the instrument sample-cell cover open.*

5.2.5 Flow-Cell Maintenance

Periodically clean the Flow Cells for the low- and high-pressure kits. Disassemble the cells and clean the glass parts as described in *Section 2.3.1* on page 22. Air dry the parts after cleaning. Clean plastic parts and tubing with laboratory detergent and warm water.

Periodically replace plastic tubing because contaminants, including microbiological growths, are difficult to remove from the inside surface of the small-bore tubing. All tubing, Flow Cells, and caps in the low pressure and high pressure kits can be steam sterilized.

Note: *Always test the system for leaks before inserting the Flow Cell into the turbidimeter.*

Coat the outside surface of the glass with a thin film of silicone oil before installation in the instrument (see *Section 2.3.2* on page 22).

Fill the system with distilled or deionized water when it is not used for short periods of time (a few hours). This minimizes air locks and build up of residue on the components.

Always disassemble, thoroughly clean, and air dry all components before long-term storage.

6.1 Recorder Output

Note: Use a twisted-pair, shielded recorder cable. Use of non-shielded recorder cables may result in radio wave emission levels higher than permitted under the compliance regulations listed. Further, the shield of the recorder cable shall be connected to the recording device chassis ground terminal to reduce the effects of unwanted interferences.

The recorder output jack on the back panel (REC) takes a ¼" phone plug wired as shown in *Figure 16*. A suitable plug is listed under Optional Accessories in *SECTION 13* on page 105. For optimum performance, use a twisted-pair, shielded recorder cable, no more than 1.8 m (6 ft) in length, with a load impedance greater than 10 kohms.

Figure 16 Recorder Phone Plug

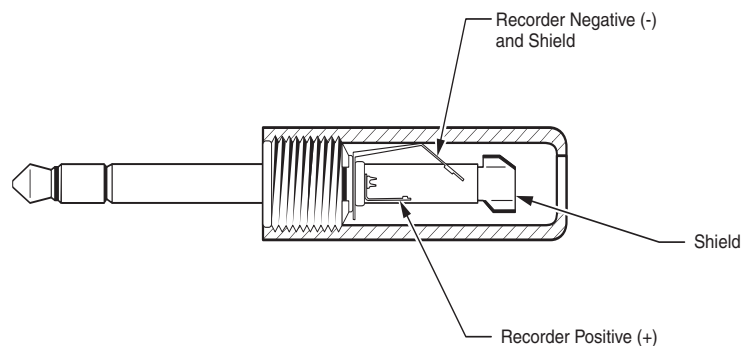

6.1.1 Setting Recorder Minimum Value

This function is used to set the minimum value of the recorder output for the current units (the selected measurement mode).

1. Enter the setup mode by pressing **SETUP**. The mode display flashes.
2. Select the number **14** using the edit keys followed by pressing the **ENTER** key. The decimal point will flash.
3. Move the decimal point to the desired location using the right arrow key, and then press **ENTER** to accept the new location. The left digit will flash.
4. Set the desired recorder minimum value using the edit keys. Press **ENTER** to accept the new setting.
5. Press **SETUP** to exit the setup mode. Pressing **UNITS/EXIT** at any time, prior to accepting the new value, exits the setup mode leaving original values intact.

Note: Recorder Minimum and Maximum values can be specified independently for each measurement mode. When the measurement mode changes, the previous settings are automatically recalled.

SECTION 6, continued

6.1.2 Setting Recorder Maximum Value

This function is used to set the maximum value of the recorder output for the current units (selected measurement mode).

1. Enter the setup mode by pressing **SETUP**. The mode display flashes.
2. Select the number **15** using the edit keys followed by pressing the **ENTER** key. The decimal point will flash.
3. Move the decimal point to the desired location using the right arrow key, and then press **ENTER** to accept the new location. The left digit will flash.
4. Set the desired recorder maximum value using the edit keys. Press **ENTER** to accept the new setting. Pressing **UNITS/EXIT** at any time, prior to accepting the new value, exits the setup mode leaving original values intact (see note under *Section 6.1.1*).

6.1.3 Setting Recorder Minimum Output

This function moves the recorder minimum output in a positive or negative direction to calibrate the recorder.

1. Enter the setup mode by pressing **SETUP**. The mode display flashes.
2. Select the number **16** using the edit keys. Press **ENTER**. The display will show **UP/DN RTN**.
3. Press the up arrow key to increase the minimum output in a positive direction. Press the down arrow key to decrease the minimum output in a negative direction. Press **ENTER** to accept the new setting.
4. Press **SETUP** to exit the setup mode. Pressing **UNITS/EXIT** at any time, prior to accepting the new value, exits the setup mode leaving original values intact.

6.1.4 Setting Recorder Full-Scale Output

This function moves the recorder full-scale output in a positive or negative direction to calibrate the recorder.

1. Enter the setup mode by pressing **SETUP**. The mode display will flash.
2. Select the number **17** using the edit keys. Press **ENTER**. The display will show **UP/DN RTX**.
3. Press the up arrow key to increase the full-scale output in a positive direction. Press the down arrow key to decrease the full-scale output in a negative direction. Press **ENTER** to accept the new setting.
4. Press **SETUP** to exit the setup mode. Pressing **UNITS/EXIT** at any time, prior to accepting the new value, exits the setup mode leaving original values intact.

SECTION 6, continued

6.2 RS232 Connection

The RS232 connection on the back panel mates with a standard RS232 connector as indicated in *Figure 17* (also see *Table 3* and *Figure 18*). The factory RS232 interface output is an eight-bit data word plus one stop bit and no parity with a baud rate of 1200. These settings can be changed with the setup menu, and are saved in non-volatile memory.

Figure 17 DB-9 Male RS232 Connector

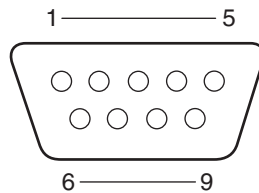
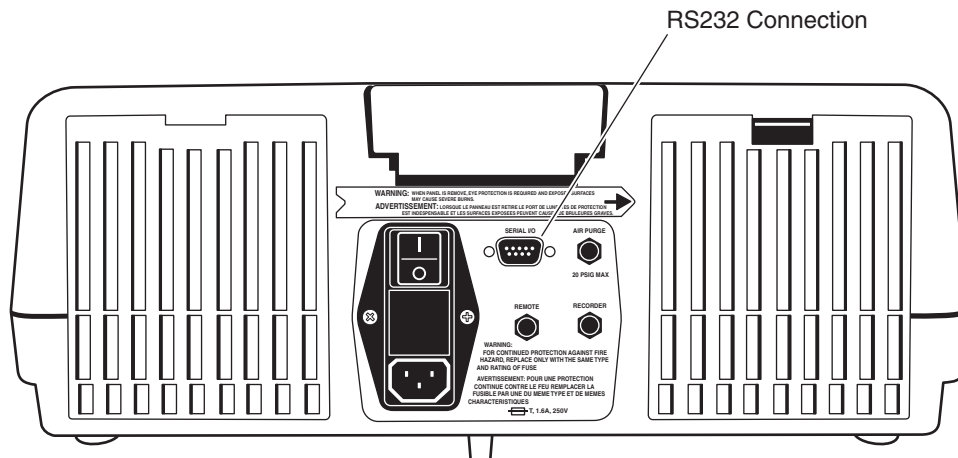

Table 3 RS232 Pin Connections

Pin	Description
2 - RXD	Receive Data
3 - TXD	Transmit Data
5 - GND	Signal Ground
6 - DSR*	Data Set Ready
SHELL - FG	Frame Ground
All other pins are not connected	

* Pin 6 is an optional printer handshake line. Do not connect when using a computer.

Figure 18 RS232 Connection



A. Baud Rate Select:

1. Press **SETUP** (the small LED mode display flashes).
2. Use the up, down and right arrow keys to enter **10** into the mode display.
3. Press **ENTER**.
4. The current baud rate flashes in the large display (1200 is the factory setting).
5. Use the up or down arrow keys to select the desired baud rate.
6. To store, press **ENTER**.
7. Press **SETUP** to exit the setup mode.

B. Character Length Select:

1. Press **SETUP** (the small LED mode display flashes).
2. Use the up, down and right arrow keys to enter **11** into the small display.
3. Press **ENTER**.
4. The current character length flashes in the large display.
5. Use the up or down keys to select the desired character length.
6. To store, press **ENTER**.
7. Press **SETUP** to exit the setup mode.

C. Stop Bit Select:

1. Press **SETUP** (the small LED mode display flashes).
2. Use the up, down and right arrow keys to enter **12** into the mode display.
3. Press **ENTER**.
4. The current number of stop bits flashes in the large display.
5. Use the up or down keys to select the desired stop bits.
6. To store, press **ENTER**.
7. Press **SETUP** to exit the setup mode.

D. Parity Select:

1. Press **SETUP** (the small LED mode display flashes).
2. Use the up, down and right arrow keys to enter **13** into the mode display.
3. Press **ENTER**.
4. The current parity selection flashes in the large display.
5. Use the up or down arrow keys to select the desired parity.

SECTION 6, continued

6. Press **ENTER**.
7. Press **SETUP** to exit the Setup mode.

6.3 Instrument Communication

Note: A specified cable or equivalent is mandatory for EC compliance (a shielded cable assembly is required).

The instrument can communicate with either a serial printer or a serial communication port on a computer (see *Figure 19* and *Figure 20*). If the RS232 feature is used for a serial printer, a printer cable assembly terminated with a standard 25-pin D connector is an optional accessory (refer to *SECTION 13* on page 105). Using a serial-to-parallel converter, the data string transmitted from the 2100AN Turbidimeter prints on any Epson compatible parallel printer that is used with IBM compatible applications.

Data is transmitted to the printer as a 39-character string plus the line feed and carriage return.

Figure 19 Typical 2100AN to Serial Printer Cable

Instrument (DB9 Female)		Printer (DB 25 Male)
3	_____	3
5	_____	7
6	_____	20
SHELL	_____	1 (SHELL)

Figure 20 Printer Format Example

```
HACH 2100AN V1.0
01/01/94 12:00:00:00

01/01/94 12:00:00:00
0.009 NTU SAMPLE#00

CALIBRATION DATA
UNITS: NTU
DATE: 01/01/94 12:00:00:00
STANDARDS:
00 0.0434
01 20.000
02 200.00
03 1000.0
04 4000.0
05 7500.0
COEFFECIENTS:
A0=602.77400
B0=0.0022002
B1=0.0006147
C0=0.0022703
C1=0.0006442
C2=-1.000184
D0=0.0022970
D1=0.0006096
D2=-0.000034
D3=-0.000126
```

SECTION 6, continued

6.4 Printer

A permanent record of test results can be obtained by using the built-in printer or transmitting through the RS232 output to an external printer or computer. *Figure 20* shows a sample printout from the built-in printer.

6.4.1 Built-In Printer

The 2100AN Turbidimeter has a built-in 28 column thermal printer. The printer is active for output when the printer selection setup (number **02**) is set to **INT** or **BOTH** (see *Section 6.4.2.2*).

Observe the following procedures with the built-in thermal printer for best results:

- Always use Hach thermal paper (Cat. No. 47090). Use of other thermal paper may result in marginal print quality and reduced print-head life.
- Leave the roll of thermal paper in the sealed plastic wrapper until the paper is used.
- Do not rub the thermal paper with a hard object.
- Do not use chemical paste on thermal paper.

Note: A red line on the edge of the thermal paper indicates when the paper supply is low.

6.4.1.1 Loading Paper into the Built-In Printer

Note: Always use Hach thermal paper (Cat. No. 47090-00). Use of other thermal paper may result in marginal print quality and reduced print-head life.

The following steps describe installation of a new roll of thermal printer paper into the 2100AN Turbidimeter. Removing the printer access door may simplify paper replacement. The printer door hinge pin (located on the left side) is slotted for easy removal when in the full open position. Open the door carefully and lift the left pin from the slot. Carefully remove the printer door. Reverse the procedure starting with the hinge pin located on the right side to reassemble.

1. Cut the end of the paper into an arrow shape using scissors.
2. Open the printer access door.
3. Insert the point of the printer paper into the paper entrance slot on the back of the printer.
4. Push the printer paper through the entrance slot until the point of the paper appears at the exit slot.
5. Pull the point of the paper out of the exit slot until the full width of the paper is visible and clear of the opening.
6. Insert the point of the printer paper through the slot in the printer access door while closing the printer door.
7. Pull the paper to advance through the printer, or press **LINE FEED** to advance the paper one line at a time.

SECTION 6, continued

6.4.2 Printer Setup Commands

6.4.2.1 Printer Speed Selection

The 2100AN Turbidimeter can be configured for fast or slow (2.5 second delay) print speed.

1. Enter the setup mode by pressing **SETUP**. The small LED mode display will flash.
2. Select the number **01** using the up, down and right arrow (edit) keys.
3. Press the **ENTER** key to activate the print speed selection mode. Use the up or down arrow keys to select the flashing **FAST PRT** for fast or **SLOW PRT** for slow print speed.
4. Press the **ENTER** key to accept the desired setting.
5. Press **SETUP** to exit the setup mode. Pressing **UNITS/EXIT** at any time, prior to accepting the new print speed setting, exits the printer setup mode leaving original settings intact.

6.4.2.2 Printer Output Selection

1. Enter the setup mode by pressing **SETUP**. The small LED mode display will flash.
2. Select the number **02** using the edit keys. Press the **ENTER** key to go into the printer setup mode.
3. Toggle through the **INT** (the built-in printer), **EXT** (the RS232 connection), or **BOTH** printer outputs using the edit keys. Press the **ENTER** key to select the desired output.
4. Press **SETUP** to exit the setup mode. Pressing **UNITS/EXIT** at any time, prior to accepting the new output setting, exits the printer setup mode leaving original settings intact.

6.4.2.3 Print Interval Setting

1. Enter the printer setup mode by pressing **SETUP**. The small LED mode display will flash.
2. Select the number **03** using the edit keys followed by **ENTER**. **MM-SS IVL** is displayed with the left digit flashing.
3. Set the minutes and seconds (**MM-SS**) for the automatic print interval time using the edit keys (**00-15** to **99-99**). To disable the print interval setting, select **00-00**. Press **ENTER** to accept the new setting.
4. Press **SETUP** to exit the setup mode. Pressing **UNITS/EXIT** at any time, prior to accepting the new value, exits the setup mode leaving original values intact.

SECTION 6, continued

6.4.2.4 Activating/Deactivating the Print Interval Feature

The print interval feature automatically prints a displayed reading (in any of the eight measurement modes) at selected print intervals. After the new print interval setting is accepted (see *Section 6.4.2.3*), the **PRINT** key functions as a toggle switch to activate and deactivate the print interval feature. Pressing the **PRINT** key prints the first reading and activates the print interval feature. The **PRINT** key annunciator lights without flashing to indicate that the print interval feature is active.

Pressing the **PRINT** key again deactivates the print interval feature. The print key annunciator flashes to indicate that the print interval selected is inactive.

6.4.2.5 Print Contrast Setting

The contrast of the printer can be adjusted to print from light to dark.

1. Enter the setup mode by pressing the **SETUP** key. The small LED mode display will flash.
2. Select the number **04** using the edit keys. Press **ENTER**.
3. Use the up and down arrow keys to adjust the contrast (0 darkest to 7 lightest). Press the **ENTER** key to accept the new contrast setting.
4. Press **SETUP** to exit the setup mode. Pressing the **UNITS/EXIT** key at any time prior to accepting the new output setting exits the contrast setup mode and leaves the original settings intact.

6.5 Using a Computer (RS232 Operating Commands)

A communication program such as *Window Terminal* or *ProComm Plus* is recommended for computer operation. Configure the communication program to 1200 baud, 8 data bits, no parity, 1 stop bit (default settings).

The following RS232 command set is available when a computer is connected to the 2100AN:

- Key in **VAL** (for value), and press enter on the computer keyboard. This action recalls the current 2100AN measurement with the measurement units.
- Key in **LST** (for list), and press enter on the computer keyboard. This action lists the calibration standards and coefficients.
- Key in **DAT** (for date), and press enter on the computer keyboard. This action recalls the current date programmed into the 2100AN. Key in **DAT=MM/DD/YY** to set a new date. Press enter on the computer keyboard to accept the new date.
- Key in **TIM** (for time/24 hour format), and press enter on the computer keyboard. This action recalls the current time programmed into the 2100AN. Key in **TIM=HH:MM** to set a new time. Press enter on the computer keyboard to accept the new time.

SECTION 6, continued

- Key in **RMN** [for recorder minimum (current units)], and press enter on the computer keyboard. This action recalls the current recorder minimum value programmed into the 2100AN. Key in **RMN=XXXXXX** to set a new recorder minimum value. Press enter on the computer keyboard to accept the new recorder minimum value (the smallest recorder minimum value setting is 0).
- Key in **RMX** [for recorder maximum (current units)], and press enter on the computer keyboard. This action recalls the current recorder maximum value programmed into the 2100AN. Key in **RMX=XXXXXX** to set a new recorder maximum value. Press enter on the computer keyboard to accept the new recorder minimum value (the largest recorder maximum value setting is 10,000).
- Key in **RTN** (for recorder trim minimum), and press enter on the computer keyboard. This action recalls the current recorder trim minimum value programmed into the 2100AN. Key in **RTN=XXXXXX** to set a new recorder trim minimum value. Press enter on the computer keyboard to accept the new recorder trim minimum value (the smallest recorder trim minimum value setting is 200).
- Key in **RTX** (for recorder trim maximum), and press **ENTER** on the computer keyboard. This action recalls the current recorder trim maximum value programmed into the 2100AN. Key in **RTX=XXXXXX** to set a new recorder trim maximum value. Press enter on the computer keyboard to accept the new recorder trim maximum value (the largest recorder trim maximum value setting is 4800).
- Key in **SAV** (for signal average buffer size), and press enter on the computer keyboard. This action recalls the current signal average buffer size programmed into the 2100AN. Key in **SAV=XX** to set a new signal average buffer size. Press enter on the computer keyboard to accept the new signal average buffer size (the default signal average buffer size is 10, and the maximum signal average buffer size is 15).

7.1 Clock Description

The 2100AN Instrument contains a battery-backed, real-time clock. This feature provides a time-date stamp on all data transmitted to the internal printer or to external devices via the RS232 Interface. Time and dated measurements, calibration records, instrument setup data and diagnostic records are recorded and maintained easily using this feature.

7.2 Setting Hours and Minutes

1. Enter the setup mode by pressing **SETUP**. The mode display will flash.
2. Select the number **05** using the up, down and right arrow (edit) keys, then press **ENTER**.
3. Set the hours and minutes (**HH-MM**) using the edit keys (24 hour format). Press **ENTER** to accept the new setting.
4. Press **SETUP** to exit the setup mode. Pressing **UNITS/EXIT** at any time, prior to accepting the new value, exits the setup mode leaving original values intact.

7.3 Setting the Month and Day

1. Enter the setup mode by pressing **SETUP**. The mode display will flash.
2. Select the number **06** using the edit keys followed by **ENTER**. Set the month and day (**MM-DD**) using the edit keys.
3. Press **ENTER** to accept the new setting.
4. Press **SETUP** to exit the setup mode. Pressing **UNITS/EXIT** at any time, prior to accepting the new value, exits the setup mode leaving original values intact.

7.4 Setting the Year

1. Enter the setup mode by pressing **SETUP**. The mode display will flash.
2. Select the number **07** using the edit keys followed by **ENTER**.
3. Set the year (**YY**) using the edit keys. Press **ENTER** to accept the new setting.
4. Press **SETUP** to exit the setup mode. Pressing **UNITS/EXIT** at any time, prior to accepting the new value, exits the setup mode leaving original values intact.

7.5 Displaying Current Time

1. Enter the setup mode by pressing **SETUP**. The mode display will flash.
2. Select the number **08** using the edit keys, then press **ENTER**. The current time is displayed (**HH-MM-SS**).
3. Press **ENTER** to display the time. Press **SETUP** to exit.

8.1 Using Cell Adapters

Cell adapters are used with the Model 2100AN Turbidimeter when sample cells smaller than the standard 25-mm cells are required. A wide variety of test tubes, sample cells and ampules can be used with the cell adapters to measure smaller sample volumes. Small-diameter sample cells are useful when only a small quantity of sample is available, the sample to be measured is ampuled and cannot be opened, or the sample is too turbid for use with the standard sample cell. A shorter light path permits measurement of high-range samples without the need for sample dilution.

Adapters are available for vial diameters of 12- to 13-mm, 16-mm and 19-mm O.D. The 12- to 13-mm adapter accommodates either 12-mm or 13-mm tubes. The minimum sample volumes that must be used are 2.5 mL for 12-mm tubes, 3.5 mL for 13-mm tubes, 5 mL for 16-mm tubes and 7 mL for 19-mm tubes.

The adapters come with a tall light shield supplied for test tubes taller than the standard cover.

Carefully select sample-cell glassware used with the adapters to be clean and free of significant scratches. The same handling and cleaning care applied to the standard 2100AN sample cells applies to the smaller cells (including the use of silicone oil on the outside of the glass).

Use the *Application-Specific Calibration* (ASC) ability of the instrument to provide direct reading of results (instead of developing a new calibration curve each time the ASC unit is measured, and calculating the concentration from the curve) (see *SECTION 10* on page 91).

8.1.1 Installing and Removing Cell Adapters

To install a Cell Adapter in the instrument's sample compartment, align the tab on the cell adapter toward the front of the instrument (see *Figure 21*).

Note: Do not force the adapter out of the compartment; serious instrument damage can occur.

Carefully pull the adapter straight up to remove. Slowly rotate the adapter 90-degrees counter clockwise if the adapter catches.

Figure 21 Cell Adapter Installation

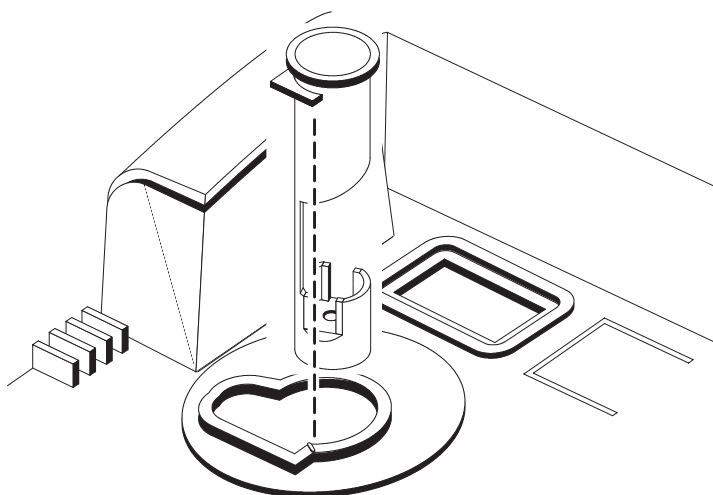

9.1 Filter Modules

A variety of filter module assemblies are available to select the wavelength of light used for measuring samples. The 2100AN Turbidimeter is supplied with an EPA Filter Assembly (*Cat. No. 30312-00*) for turbidity measurement and a 455-nm Interference Filter Assembly (*Cat. No. 19998-00*) for use in color measurement (APHA Pt-Co).

The EPA Filter Assembly is required for turbidity measurements reported for United States Environmental Protection Agency (USEPA) National Primary Drinking Water Regulations (NPDWR) or National Pollutant Discharge Elimination System (NPDES) permits.

The 455-nm Interference Filter Assembly is used in the Color Units (CU) measurement mode. The unit of measure is Platinum-Cobalt (Pt-Co) Color Units (see *Section 9.2.1*).

Six optional Interference-Filter Assemblies also are available:

Cat. No.	Wavelength
30397-00	Set of all 6 Filter Assemblies
30363-00	410 nm
30367-00	500 nm
30371-00	560 nm
30373-00	610 nm
30376-00	810 nm
19999-00	860 nm

The 860-nm Interference Filter Assembly (Cat. No. 19999-00) operates the 2100AN at an 860-nm wavelength. This wavelength is specified by *ISO 7027* for turbidity measurement.

An empty filter holder assembly (Cat. No. 30398-00) can be purchased for assembly of a custom filter. The filter holder assembly accommodates a filter 25.4 mm (1 inch) in diameter and 6.35-mm ($\frac{1}{4}$ inch) thick.

9.1.1 Installing Filter Assemblies

1. Ensure the filter is clean and free from visible damage.

Note: Handle the filter assemblies with care; the interference filters installed in the assemblies are fragile. Clean the filters with lens tissue.

Note: Periodically inspect the filter glass for scratches or other signs of degradation. If a cloudy halo appears around the outside perimeter, the filter material is delaminating, and performance is questionable. Replace the filter.

2. Hold the tab on the filter assembly, and insert the filter with the arrows pointing toward the front of the turbidimeter.
3. Press the filter assembly all the way down into the housing.
4. To remove a filter assembly from the instrument, grasp the tab and pull straight up. Store the filter assembly in a clean environment.

SECTION 9, continued

9.1.2 Developing Applications Using Alternate Wavelengths

It may not be possible to complete measurements in all units of measure for a particular application using the optional filter assemblies (especially nephelometric modes that include NTU, EBC, Neph and ASC units). For example, the NTU unit of measure may not be suitable at a 560-nm wavelength for a particular sample, but the measurement could be completed in Absorbance (A) or Transmittance (%T) modes.

Insufficient light is the problem that may be encountered most often when using the NTU, EBC, Neph and ASC units of measure with the optional filters. The 2100AN provides a low-light warning indicated by a flashing lamp annunciator. This limitation can be overcome using the cell adapters and smaller sample cells to provide a shorter light path.

To develop applications using the optional filter assemblies:

1. Prepare a series of standards solutions that span the range of interest.
2. Select the filter assembly providing the desired wavelength, and install it in the instrument.
3. Select the desired unit of measure.
4. Measure the standards, and plot the response.
5. Repeat the test using one of the optional cell adapters and a smaller sample cell if a low-light indication occurs.

Many low-light conditions encountered in developing applications at alternate wavelengths can be resolved with the proper selection of the measurement unit, wavelength and cell-path length.

9.2 Measurements in Color, % Transmittance and Absorbance

The 2100AN provides for measurement and direct measurement of scattered, percent transmitted (%T) or absorbed (Abs) light. Therefore, turbidity, color (Pt-Co units), %T and Abs can all be determined on a single sample. Hach Company recommends using the Flow Cell in these measurement modes for best results.

Color methods using a wavelength other than 455 nm can be developed using selected interference filter assemblies.

9.2.1 Using Color Units (Platinum Cobalt Color Units Calibration Procedure)

Note: The 15 CU Pt-Co standard is recommended when measuring low-color concentrations. Use the 500 Pt-Co CU standard if concentrations are expected to be greater than 30 CU.

Note: Prepare a 15 CU standard by diluting 15 mL of the 500 CU standard (Cat. No. 1414-53) to 500 mL with deionized water in a volumetric flask.

Note: Use of a Flow-Cell Kit is recommended. A Flow-Cell Kit is required to achieve cited instrument accuracy and reproducibility specifications. Use of a Flow Cell is especially important when measuring low level color.

SECTION 9, continued

Before measuring Color, calibrate the instrument using a blank solution and a known standard. Hach recommends a blank solution of deionized water and a standard of 15 or 500 Platinum Cobalt (Pt-Co) Color Units. After inserting the 455-nm Color Filter Assembly in the instrument, calibrate the Color Unit using *Section 9.2.1.1*.

9.2.1.1 Color Measurement and Calibration Procedure

Use the following procedure to make color measurements or recalibrate. To make measurements based on the existing calibration, reestablish the zero reference point and insert sample cells containing sample.

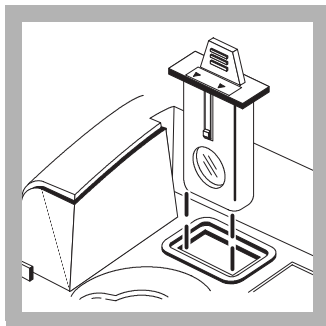

1. Insert the appropriate Filter Assembly in the filter assembly compartment. Use the 455-nm Filter Assembly for Color measurement (Pt-Co CU).

Note: Flow-Cell Kit use is recommended. A Flow-Cell system is required to achieve cited instrument accuracy and reproducibility specifications.

Note: Instrument warm-up stabilization time for Color measurement is 30 minutes. Typical application is to leave the instrument on 24 hours a day.

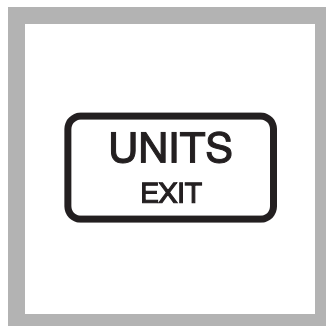

2. Press the **UNITS/EXIT** key until the units display reads ----CU. Press the **CAL/ZERO** key. The display reads “**ZERO**” CU.

Note: The instrument is simultaneously zeroed for Color, Transmittance, and Absorbance modes.

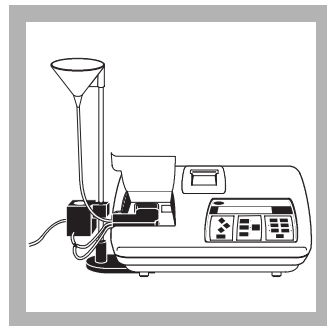

3. Using the manual Flow-Cell Kit, insert the Flow-Cell Assembly into the cell holder. Press the inlet and outlet tubes into the slots on the instrument's top enclosure and cover with the flow-cell light cover.

Note: Refer to *Section 5.2.1* on page 57.

Note: Thoroughly clean the Flow Cell (see *Section 5.2.5* on page 69). After cleaning, apply a thin coat of silicone oil to the outside of the cell (see *Section 2.3.2.1* on page 23).

Note: The instrument's cell cover does not close when the Flow Cell is installed.

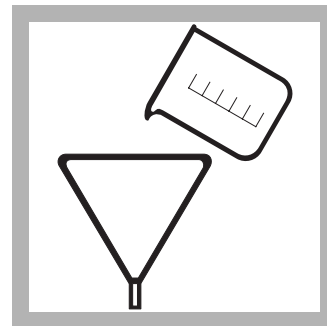

4. Carefully pour 250 mL of deionized water into the Inlet Reservoir.

Note: Flow rate through the Flow Cell is controlled by adjusting the height of the Collection Drain Assembly on the Support Rod (see *Section 5.2.1.4* on page 59).

Note: Always slowly pour sample down the inside edge of the reservoir to minimize entrapment of air bubbles in the sample.

SECTION 9, continued

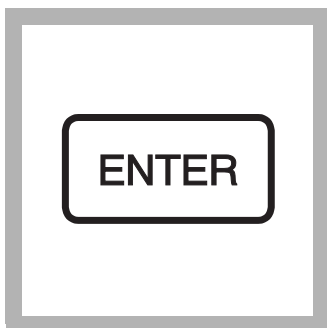

5. Press **ENTER**. The display reads **30** seconds and counts toward **0**. After time expires, the display reads 500 CU (or the last calibrated value), and the first digit flashes.

Note: To reestablish the reference zero point and make measurements based on the current calibration, skip to step 9 -OR- to calibrate proceed to step 6.

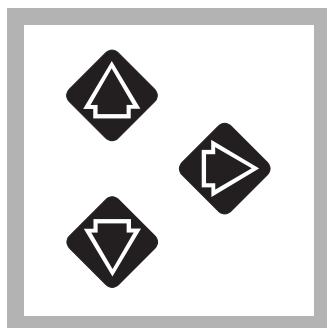

6. Use the edit keys to change the display to read the known color units of the prepared standard.

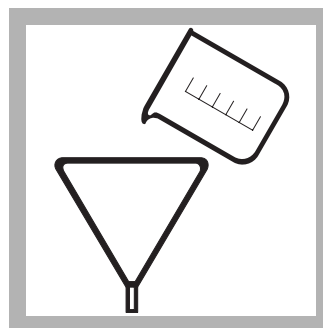

7. Carefully pour 250 mL of the known standard into the Inlet Reservoir.

Note: Always slowly pour sample down the inside edge of the reservoir to minimize entrapment of air bubbles in the sample.

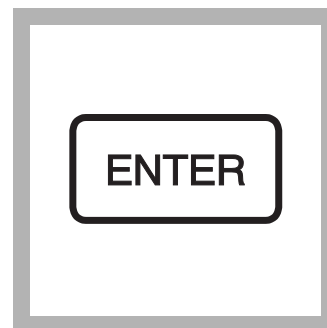

8. Press **ENTER**. The display reads 30 seconds, and counts toward **0**. The edited concentration value is displayed.

The calibration is complete; skip to step 10.

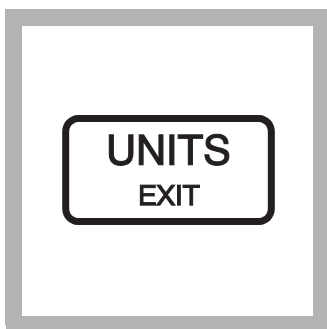

9. Press **UNITS/EXIT**.

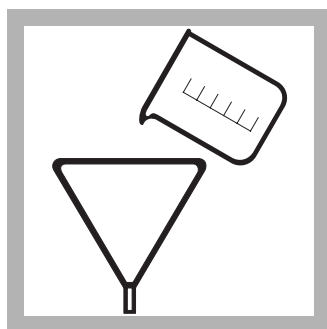

10. Carefully pour 250 mL of sample into the Inlet Reservoir. Read and record the result.

Note: Signal Average can be selected on or off (see Section 3.1.3 on page 38).

Note: Automatic or Manual Range can be selected (see Section 3.1.1 on page 37).

Note: A time-date stamp, measurement record can be printed or transmitted via RS232 by pressing the **PRINT** key.

SECTION 9, continued

- Reestablish the analytical zero reference point (re-zero) for the best possible accuracy and reproducibility. Repeat this procedure when a measurement is not taken for several hours.
- Best accuracy and reproducibility are achieved using a Flow-Cell Kit (see *SECTION 5* on page 55). A Flow-Cell system is required to meet the stated instrument specifications. If a Flow Cell is not used, match sample cells using the %T or Absorbance modes and the procedure described in *Section 2.3.4.2* on page 26).
- Color, %T and Absorbance measurements use the same “Zero” reference point. The Absorbance, %Transmittance and Color Unit measurement modes are re-zeroed simultaneously. Color, Absorbance and %Transmittance can be measured on a single sample after establishing a zero reference in any of the three modes.

9.2.3 Using Transmittance Units (Transmittance 100% Procedure)

A blank solution (100% transmittance) must be read before the transmittance reading mode can be used. This normally is DI water. After inserting an appropriate color filter in the instrument, transmittance is set to 100% by the following procedure:

1. Select transmittance by pressing the **UNITS/EXIT** key until the units display shows “%T.”
2. Press the **CAL/ZERO** key to select 100 %T.
3. The main display flashes **100%**, and the mode display reads **00**. Insert the blank solution, close the cell cover, and press **ENTER** to read the blank. The display counts down from 30 to 0 while the blank is being read. The display reads 100 %T after time expires.
4. Install a sample cell filled with the sample to be measured. The %Transmittance result is shown on the large display.

9.2.4 Using Absorbance Units (Absorbance Zero Procedure)

A blank solution (zero absorbance) must be read before the absorbance reading mode can be used. This normally is DI water. After inserting an appropriate color filter in the instrument, absorbance is zeroed by the following procedure.

1. Select absorbance by pressing the **UNITS/EXIT** key until the units display shows **A**.
2. Press the **CAL/ZERO** key to select the zero.
3. The main display flashes **ZERO**, and the mode display reads **00**. Insert the blank solution, close the cell cover, and press **ENTER** to read the blank.

The display counts down from 30 to 0 while the standard is being read. The display reads **0.000 A** after time expires.

4. Install a sample cell filled with the sample to be measured. The absorbance result is shown on the large display.

10.1 Application Specific Methods

Application Specific Calibration (ASC) measurement modes provide the capability to make nephelometric measurement with direct readout of units other than NTU. The unit of measurement, initially referred to as -1- and -2-, can be specified (edited) by choosing alpha numeric characters during method entry.

ASC methods are developed by measuring specific known standards in the NTU mode. Then, data pairs (*NTU vs. Know Standard*) are keyed into the instrument memory (refer to *Section 10.2.1*). After entry, the instrument displays direct reading measurements in the custom unit of measure. For custom method development, consider the following information:

- Cell adapters are available to accommodate 12- and 13-, 16- or 19-mm glassware in place of the standard 25-mm sample cells.
- Optional interference filter modules can be used to select the wavelength of light used for measurement (see *Section 9.1.2* on page 86).

The 2100AN Laboratory Turbidimeter can be used for application specific measurements when predefined units or standard sample cells are not appropriate. Two user-defined units of measure (ASC -1- and -2-) let the user define the unit of measure. For example, an application for monitoring oil in water can be assigned a unit of OIW, and up to eight calibration points can be stored for the application specific calibration.

Development of application specific measurements requires a thorough understanding of the sample being measured. As a general rule, use the following minimum, sample criteria for successful development of custom applications.

- Use a homogeneous sample.
- Determine the effect of temperature on the sample. Provide a means to control temperature if measurements vary significantly with temperature.
- Use a well-defined sample. That is, know all of the variables in the sample that affect absorbance or scatter light. For example, to measure oil in water, suspended oil must be the primary variable causing light to scatter or absorb. If other variables in the sample matrix also affect the scattered light detection, there is no way to discriminate between changes in concentration of suspended oil and changes in other sample variables.

SECTION 10, continued

10.2 Application Specific Calibrations

Nephelometric analysis can yield a nonlinear calibration curve. The 2100AN can store two ASC curves with up to 8 data pairs in each.

The instrument uses point-to-point interpolation between entered standards for these calibrations. A series of small, straight lines approximating the nonlinear curve is generated. Before using ASC measurement modes, the following important points must be understood and/or implemented:

- At a minimum, ASC curves must contain linear portions because the 2100AN calculates only point-to-point slopes. The instrument measurements do not utilize linear regression (least-squares-best-fit) analysis.
- Proper calibration of the instrument for turbidity measurement with Formazin primary standards is required; the ASC is based on turbidity units in NTU as the independent variable and the user-defined standards as the dependent variable.
- The sample must be studied in advance to determine the appropriate Cell Adapter (when needed) and Filter Assembly (see *Section 8.1* on page 83, *Section 9.1* on page 85, and *Section 9.1.2* on page 86).
- Prepare a series of standards for the desired ASC unit. Select and install an appropriate Cell Adapter (when needed) and Filter Assembly. Measure the turbidity of the standards in NTUs. Record the results, and plot the prepared standards vs. their corresponding turbidity in NTUs. (See *Table 4* as an example).
- Always measure the NTU value of the known standard in the same size vial to be used for the ASC unit measurement.

Table 4 Standards

Point Number	NTU	Concentration (mg/L)
1	0.000	0
2	0.318	10
3	0.542	20
4	0.663	30
5	0.709	40

Either ASC can be edited at any time eliminating the need to repeat the calibration. The sample is under-range if the display flashes 0s; when measuring Color, Absorbance or Transmittance, re-establish the analytical reference point and measure again. Additionally, make sure the expected reading is positive when measuring Absorbance. To measure samples with negative Absorbance, establish the analytical zero using the sample with the greatest absorbance, and read the sample with the least absorbance. Report the reading as negative absorbance.

SECTION 10, continued

10.2.1 Initial ASC Entry

Up to 8 standards can be entered in either of the two Application Specific Calibrations (user-defined methods denoted by “-1-” and “-2-” as shipped from Hach). *Standards must be entered in order of increasing turbidity.*

A record of either ASC can be obtained via the printer for later analysis (see *Section 10.3* on page 95). In *Table 4*, a nonlinear calibration is constructed from five standards of known mg/L concentrations. Corresponding NTU values are determined by measuring the known standards with the 2100AN Turbidimeter (verify instrument calibration with StablCal® Sealed Vial Standards prior to making NTU measurements, refer to *Section 3.2.6* on page 47).

The following step-by-step procedures (*Sections 10.2.1.1 through 10.6*) demonstrate programming new ASC data, reviewing entered ASC data, editing an ASC data point, deleting a single ASC data point, and deleting all ASC data points.

10.2.1.1 Programming New ASC Data

1. Press the **UNITS/EXIT** key until the desired ASC unit name appears (-1- or -2- factory defaults).
2. Press the **CAL/ZERO** key to enter the ASC calibration mode. The left digit of the -1- or -2- will flash.
3. Use the Arrow Keys to enter a three-digit calibration name. This name cannot be one of the predefined units (NTU, EBC, NEP, %T, A, CU, -1- or -2-). Press **ENTER** to accept the units name.

Note: *The ASC calibration name can not be one of the predefined units (NTU, EBC, NEP, %T, A, CU, -1- or -2-). Error message **ERR12** is displayed at this point if any of these predefined units are entered. Press **ENTER** to clear the error message and return to the -1- or -2- entry modes.*

4. The mode display flashes 01 to indicate that data point 1 is shown in the large LED display. The blank spaces in front of the NTU units (---- NTU) indicate no value is assigned to data point 1.
5. Press the Right Arrow key to initiate editing of data point 1. The large display shows 0.0000 with the decimal flashing. Press **ENTER** to accept the decimal point location. The left digit of the large display flashes. Press **ENTER** to accept 0.0000 as the data point 1 value (NTU).
6. The large display shows **0.0000 MGL** with the decimal point flashing. Press **ENTER** to accept the decimal point location. The left digit of the large display flashes. Press **ENTER** to accept **0.0000** as the MGL value of the first point.
7. The mode display flashes **02** to indicate that data point 2 is shown in the large LED display. The blank spaces in front of the NTU units (---- NTU) indicate no value is assigned to data point 2.
8. Press the Right Arrow key to initiate editing of point 2. The large LED display shows **0.0000** with the decimal flashing. Press **ENTER** to accept the decimal point location.

SECTION 10, continued

9. The left digit flashes. Use the edit (Arrow) keys to change the displayed number to **0.3180**. Press **ENTER** to accept **0.3180** as the point 2 value (NTU)
10. The large display shows **0.0000 MGL** with the decimal point flashing. Press the Right Arrow key once to move the flashing decimal point one position to the right. Press **ENTER** to accept the decimal point location. The left digit begins flashing. Use the Arrow keys to change the displayed number to **10.000**. Press **ENTER** to accept **10.000** as the point 2 MGL value.
11. The mode display flashes **03** to indicate that point **3** is shown in the large LED display. The blank spaces in front of the NTU units (---- NTU) indicate no value is assigned to point 3.
12. Press the Right Arrow key to initiate editing of point 3. The large LED display shows **0.0000** with the decimal flashing. Press **ENTER** to accept the decimal point location. The left digit flashes. Use the edit keys to change the displayed number to **0.5420**. Press **ENTER** to accept **0.5420** as the point 3 value (NTU).
13. The large display shows **0.0000 MGL** with the decimal point flashing. Press the Right Arrow key once to move the flashing decimal point one position to the right. Press **ENTER** to accept the decimal point location. The left digit begins flashing. Use the edit keys to change the displayed number to **20.000**. Press **ENTER** to accept **20.000** as the point 3 MGL value.
14. The mode display flashes **04** to indicate that point **4** is shown in the large LED display. The blank spaces in front of the NTU units (---- NTU) indicate no value is assigned to point 4.
15. Press the right arrow key to initiate editing of point 4. The large LED display shows **0.0000** with the decimal flashing. Press **ENTER** to accept the decimal point location. The left digit flashes. Use the edit (Arrow) keys to change the displayed number to **0.6630**. Press **ENTER** to accept **0.6630** as the point 4 value (NTU).
16. The large display shows **0.0000 MGL** with the decimal point flashing. Press the right arrow key once to move the flashing decimal point one position to the right. Press **ENTER** to accept the decimal point location. The left digit begins flashing. Use the edit (Arrow) keys to change the displayed number to **30.000**. Press **ENTER** to accept **30.000** as the point 4 MGL value.
17. The mode display flashes **05** to indicate that point **5** is shown in the large LED display. The blank spaces in front of the NTU units (---- NTU) indicate no value is assigned to point 5.
18. Press the right arrow key to initiate editing of point 5. The large LED display shows **0.0000** with the decimal flashing. Press **ENTER** to accept the decimal point location. The left digit flashes. Use the edit keys to change the displayed number to **0.7090**. Press **ENTER** to accept **0.7090** as the point 5 value (NTU).
19. The large display shows **0.0000 MGL** with the decimal point flashing. Press the right arrow key once to move the flashing decimal point one position to the right. Press **ENTER** to accept the decimal point location. The left digit begins flashing. Use the edit keys to change the displayed number to **40.000**. Press **ENTER** to accept **40.000** as the point 5 MGL value.

SECTION 10, continued

20. The mode display flashes **06** to indicate that point **6** is shown in the large LED display. The blank spaces in front of the NTU units (----- NTU) indicate no value is assigned to point 6.

*Note: Press **UNITS/EXIT** at any time up to this point to exit the ASC calibration procedure leaving the previous calibration in effect.*

21. All points now are entered. Press **CAL/ZERO** to store the new ASC calibration.

*Note: Error message **ERR13** is displayed at this point if NTU values are not entered in ascending order or only one point has been entered. Press **ENTER** to clear the error message and review the NTU values with the up and down arrow keys (see Section 10.4 for more information).*

10.3 ASC Review

Press **UNITS/EXIT** until the desired ASC unit name appears in the display (MGL in the previous example). Press **CAL/ZERO** to enter the ASC calibration mode. The large display flashes **EDIT?**. Press the **PRINT** key for a table printout of the ASC points. A graph of the ASC points also is printed if the internal printer is enabled. Press **UNITS/EXIT** to return to the reading mode.

10.4 Editing an ASC Point

Any ASC unit name or data pair can be changed. The MGL unit name is changed to PPM in the following example:

1. Press **UNITS/EXIT** until the desired ASC unit name appears. Press **CAL/ZERO** to select the ASC calibration mode. The large display flashes **EDIT?**. Press **ENTER** to initiate editing. The left digit of the unit description flashes. Edit the unit name with the arrow keys followed by **ENTER** to accept.

2. The NTU portion for point 4 is changed from **0.6630 NTU** to **0.7010 NTU**.

The mode display flashes **01** to indicate that the point 1 value of **0.0000 NTU** is shown in the large LED display. Press the up arrow key until **04** flashes in the mode display and **0.6630 NTU** appears in the large display. Press the right arrow key to initiate editing of point number 4.

3. The large display shows **0.6630 NTU** with the decimal point flashing. Press **ENTER** to accept the decimal point location. The left digit flashes. Use the arrow keys to change the displayed number to **0.7010**. Press **ENTER** to accept **0.7010** as the new point 4 value (NTU).
4. The large display shows **30.000 PPM** with the decimal point flashing. Press **ENTER** to accept the decimal point location. The left digit flashes. Press **ENTER** to accept **30.000** as the point 4 PPM value.
5. The mode display flashes **05** to indicate that the point 5 value of **0.7090 NTU** is shown in the large LED display.

*Note: Press **UNITS/EXIT** at any time up to this point to exit the ASC calibration procedure leaving the previous calibration in effect.*

6. Point 4 now is entered. Press **CAL/ZERO** to store the edited ASC calibration.

SECTION 10, continued

10.5 Deleting a Single ASC Point

Any ASC data point can be deleted individually. Point 3 of the MGL example is deleted in the following procedure.

1. Press **UNITS/EXIT** until the desired ASC unit name appears (MGL in this example). Press **CAL/ZERO** to select the ASC calibration mode. The large display flashes **EDIT?**. Press **ENTER** to initiate editing. The left digit of the unit description flashes. Press **ENTER** to accept the unit's name.
2. The mode display flashes **01** to indicate that the point 1 value of **0.0000 NTU** is shown in the large LED display. Press the up arrow key until **03** flashes in the mode display and **0.5420 NTU** appears in the large display. Press the right arrow key to initiate editing of point number 3.
3. The large display shows **0.5420 NTU** with the decimal point flashing. Press **ENTER** to accept the decimal point location. The left digit flashes. Use the up and down arrow keys until an **X** appears in the display. Press **ENTER** to delete the point.
4. The mode display flashes **03** to indicate that point 3 is displayed. The large LED display of **----- NTU** indicates the point 3 value is deleted. Press **CAL/ZERO** to store the modified ASC calibration.

Note: *The deleted data point is replaced by blanks and is not used in the calibration curve calculation.*

10.6 Deleting All ASC Points

Either of the ASC nonlinear curves can be deleted completely and returned to the factory **-1-** or **-2-** setting. The MGL calibration is deleted in the following example.

1. Press **UNITS/EXIT** until the desired ASC unit name appears (MGL for this example). Press **CAL/ZERO** to enter the ASC calibration mode. The large display flashes **EDIT?**. Press up or down until **DEL?** flashes in the display. Press **ENTER** to delete all MGL data and return to **-1-** or **-2-**.

Note: *All of the data for the selected ASC unit is cleared when **ENTER** is pressed with **DEL?** flashing in the display. Press **UNITS/Exit** before pressing **ENTER** to cancel deleting the ASC data points.*



INSTALLATION AND MAINTENANCE

Some of the following manual sections contain information in the form of warnings, cautions and notes that require special attention. Read and follow these instructions carefully to avoid personal injury and damage to the instrument. Only personnel qualified to do so, should conduct the installation/maintenance tasks described in this portion of the manual.

Certains des chapitres suivants de ce mode d'emploi contiennent des informations sous la forme d'avertissements, messages de prudence et notes qui demandent une attention particulière. Lire et suivre ces instructions attentivement pour éviter les risques de blessures des personnes et de détérioration de l'appareil. Les tâches d'installation et d'entretien décrites dans cette partie du mode d'emploi doivent être seulement effectuées par le personnel qualifié pour le faire.

Algunos de los capítulos del manual que presentamos contienen información muy importante en forma de alertas, notas y precauciones a tomar. Lea y siga cuidadosamente estas instrucciones a fin de evitar accidentes personales y daños al instrumento. Las tareas de instalación y mantenimiento descritas en la presente sección deberán ser efectuadas únicamente por personas debidamente cualificadas.

Einige der folgenden Abschnitte dieses Handbuchs enthalten Informationen in Form von Warnungen, Vorsichtsmaßnahmen oder Anmerkungen, die besonders beachtet werden müssen. Lesen und befolgen Sie diese Instruktionen aufmerksam, um Verletzungen von Personen oder Schäden am Gerät zu vermeiden. In diesem Abschnitt beschriebene Installations- und Wartungsaufgaben dürfen nur von qualifiziertem Personal durchgeführt werden.

Algumas das seguintes secções do manual contêm informações em forma de advertências, precauções e notas que requerem especial atenção. Leia e siga atentamente as presentes instruções para evitar ferimentos pessoais e não danificar o instrumento. As tarefas de instalação/manutenção descritas nesta parte do manual só poderão ser executadas por pessoal qualificado para o fazer.

11.1 Cleaning

Keep the turbidimeter and accessories as clean as possible; use a mild detergent and water when necessary to clean the enclosure and keypad. Wipe up spills promptly. Wash sample cells with nonabrasive laboratory detergent, rinse with distilled or demineralized water, and air dry. Avoid scratching the glass cells, and wipe all moisture and fingerprints off of the cells before inserting them into the instrument (refer to *Section 2.3.1* on page 22).

WARNING

Turn the 2100AN Turbidimeter off and disconnect the power before cleaning the instrument.

ATTENTION

Eteindre le turbidimètre 2100AN et débrancher l'alimentation électrique avant de nettoyer l'appareil.

ADVERTENCIA

Apague el Turbidímetro 2100AN antes de limpiar el instrumento.

WARNHINWEIS

Vor der Reinigung muß das Trübungsmeßgerät 2100AN abgestellt und der Netzstecker gezogen werden.

AVISO

Apague o Turbidímetro 2100AN e desligue a corrente eléctrica antes de limpar o instrumento.

11.2 Lamp Replacement

Use only the Lamp Replacement Kit (Cat. No. 47089-00). The lamp assembly includes the lamp with leads, the lamp retainer, and the lamp holder. Replace the lamp as follows:

1. Turn the instrument off, and disconnect the power cord from the back panel receptacle.

CAUTION

The lamp must be cool before removal from the instrument.

PRUDENCE

La lampe doit être froide avant de la retirer de l'appareil.

PRECAUCION

La lámpara debe dejarse enfriar antes de intentar quitarla del instrumento.

VORSICHT

Die Lampe muß vor der Entnahme aus dem Gerät abgekühlt sein.

PRECAUÇÃO

A lâmpada deverá estar esfriada antes de tirá-la do instrumento.

CAUTION

Wear protective eye wear if the lamp is turned on while the lamp cover is removed.

PRUDENCE

Porter des lunettes de protection si la lampe est allumée, alors que le capot de la lampe est retiré.

PRECAUCION

Use protección de ojos cuando la lámpara esté encendida y su cubierta protectora esté fuera de posición.

VORSICHT

Wenn die Lampe bei abgenommener Lampenabdeckung brennt, ist ein Augenschutz zu tragen.

SECTION 11, continued

PRECAUÇÃO

Quando a Lâmpada estiver acesa e a proteção de lâmpada estiver removida, use protetor ocular.

2. Remove the access panel to expose the lamp compartment (see *Figure 22*). Squeeze the two latch tabs together, and pull out on the panel.

Figure 22 Lamp Replacement

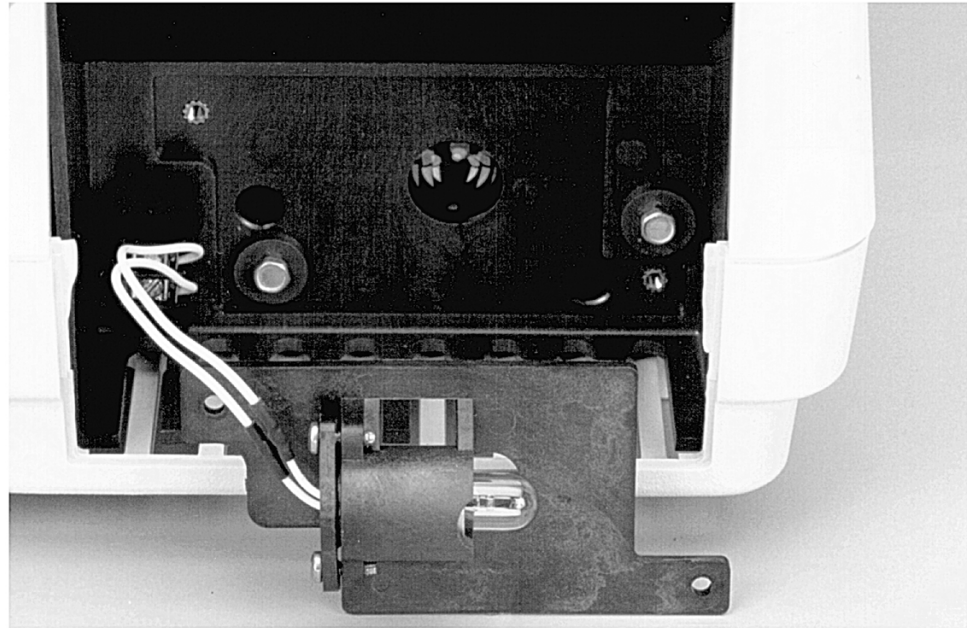

3. Use a small screwdriver to loosen the two screws securing the lamp leads in the lamp terminal block. Pull the leads free.
4. Remove the two Phillips screws securing the lamp holder in the instrument (upper left-hand corner and lower right-hand corner). Remove the entire lamp assembly.

Note: *Do not touch the lamp; oil from skin will cause damage. Clean the lamp with alcohol if necessary.*

5. Secure the new lamp assembly in place using the two Phillips screws (do not over-tighten).
6. Insert one stripped lamp lead under each of the positions in the lamp terminal block. Either lamp lead can be inserted in either terminal block position. Tighten the terminal block screws to secure the leads (do not over-tighten). Replace the lamp compartment access panel and restore power to the instrument.

Note: *The lamp output is stabilized at Hach; no "burn-in" time is required. However, warm-up the lamp for a minimum of 60 minutes before calibrating the instrument.*

7. Recalibrate the instrument as described in *Section 3.2.4* on page 43. New turbidity standards must be prepared (refer to *Section 3.2.2* on page 41 and *Section 3.2.3* on page 41).

12.1 Introduction

The Model 2100AN Laboratory Turbidimeter incorporates a number of error codes and self-diagnostic functions for convenient and effective system troubleshooting.

12.2 Error Codes

Error codes may be initiated due to instrument malfunction or operator error. ERRXX error codes are cleared from the display by pressing the **ENTER** key. The instrument continues operating in the error condition; a calibration in progress can be continued. *Table 5* lists the error codes displayed for specific conditions.

Table 5 Error Codes

Code	Probable Cause	Corrective Action
ERR01	Dilution water is greater than 0.5 NTU	Start calibration over with better quality dilution water before use.
ERR02	Two calibration standards have the same value, or their difference is less than 60.0 NTU.	Recheck preparation of standards and repeat calibration.
ERR03	Low light error	Re-insert sample. Check that lamp is on. Check for obstructed light path. Dilution may be necessary.
ERR04	Memory malfunction	Switch instrument off and back on with I/O. Call Hach service.
ERR05	A/D over-range	Be sure cover is closed and appropriate Filter Module is installed. Call Hach service.
ERR06	A/D under-range	Check light path for obstruction. Call Hach service.
ERR07	Light leak	Be sure cover is closed. Switch instrument off and back on with I/O.
ERR08	Bad lamp circuit	Ensure lamp lead ends are not touching. Ensure lamp leads are inserted in terminal block. Call Hach service.
ERR09	Printer time-out error	Check that external printer is properly connected. Check that external printer is selected (on-line).
ERR10	System voltage out of range	Switch instrument off and back on with I/O. Call Hach service.
ERR11	System loop test error.	Switch instrument off and back on with I/O. Call Hach service.
ERR12	ASC units name error.	Enter an ASC unit name that is not one of the default units (NTU, EBC, etc.).
ERR13	ASC points error.	ASC points must be entered in ascending NTU order. At least two ASC points must be entered.
ERR14	Invalid time error.	Time must be between 00-00 and 23-59.
ERR15	Invalid date error.	Date must be between 01-00 and 12-31.

SECTION 12, continued

12.3 Diagnostic and Setup Functions

The diagnostic mode accesses information about instrument operation and often is used when servicing the equipment. Enter the diagnostic mode by pressing the **SETUP** key. Exit from this mode at any time by pressing the **UNITS/Exit** key.

12.3.1 Basic Diagnostic Codes

Access the *Table 6* diagnostic information by entering the appropriate code:

Table 6 Diagnostic and Setup Codes

Code	Display	Description
0	BEEP ON/ BEEP OFF	Keyboard Beeper On/Off
1	FST PRT	Fast/Slow Print Device
2	BOTH PRT	Printer Output Selection
3	XXXXXIVL	Print Interval
4	XXXXXCON	Internal Printer Contrast
5	XX-XXH/M	Set hour/minutes
6	XX-XXM/D	Set month/day
7	YEARXX	Set year
8	XX XX XX	Display current time
9	SIGAVGXX	Signal Average Buffer Setting
10	1200BD	RS232 Baud Rate Select
11	8 CL	RS232 Character Length Select
12	1 SB	RS232 Stop Bit Select
13	NONE PAR	RS232 Parity Select
14	XXXXXRMN	Setting Recorder Minimum value
15	XXXXXRMX	Setting Recorder Maximum value
16	XXXXXRTN	Setting Recorder Minimum Output
17	XXXXXRTX	Setting Recorder Full-Scale Output
18	ZERO REC	Force Recorder to Zero Scale
19	HALF REC	Force Recorder to Half Scale
20	FULL REC	Force Recorder to Full Scale
21	PRINT TST	Printer Test
22	*	Display Test
23	*	Keyboard Test
24	*	Memory Test
25	XXXXXNIO	Ninety Degree Detector Millivolts, Gain 1
26	XXXXXNI1	Ninety Degree Detector Millivolts, Gain 10
27	XXXXXNI2	Ninety Degree Detector Millivolts, Gain 100
28	XXXXXNI3	Ninety Degree Detector Millivolts, Gain 1000
29	XXXXXFSO	Forward Scatter Detector Millivolts, Gain 1
30	XXXXXFS1	Forward Scatter Detector Millivolts, Gain 10
31	XXXXXFS2	Forward Scatter Detector Millivolts, Gain 100
32	XXXXXFS3	Forward Scatter Detector Millivolts, Gain 1000
33	XXXXXTRO	Transmitted Detector Millivolts, Gain 1
34	XXXXXTR1	Transmitted Detector Millivolts, Gain 10

SECTION 12, continued

Table 6 Diagnostic and Setup Codes (Continued)

Code	Display	Description
35	XXXXXTR2	Transmitted Detector Millivolts, Gain 100
36	XXXXXTR3	Transmitted Detector Millivolts, Gain 1000
37	XXXXXTR4	Transmitted Detector Millivolts, Gain 10,000
38	XXXXXTR5	Transmitted Detector Millivolts, Gain 100,000
39	XXXXXTR6	Transmitted Detector Millivolts, 1,000,000
40	XXXXXBS0	Back Scatter Detector Millivolts, Gain 1
41	XXXXXBS1	Back Scatter Detector Millivolts, Gain 10
42	XXXXXBS2	Back Scatter Detector Millivolts, Gain 100
43	XXXXXBS3	Back Scatter Detector Millivolts, Gain 1000
44	XXXXXVL0	A/D Reference Low Millivolts, Gain 1
45	XXXXXVL1	A/D Reference Low Millivolts, Gain 10
46	XXXXXVL2	A/D Reference Low Millivolts, Gain 100
47	XXXXXVL3	A/D Reference Low Millivolts, Gain 1000
48	XXXXXVM0	A/D Reference Medium Millivolts, Gain 1
49	XXXXXVM1	A/D Reference Medium Millivolts, Gain 10
50	XXXXXVM2	A/D Reference Medium Millivolts, Gain 100
51	XXXXXVM3	A/D Reference Medium Millivolts, Gain 1000
52	XXXXXVH0	A/D Reference High Millivolts, Gain 1
53	XXXXXVH1	A/D Reference High Millivolts, Gain 10
54	XXXXXVH2	A/D Reference High Millivolts, Gain 100
55	XXXXXVH3	A/D Reference High Millivolts, Gain 1000
56	XXXXXGD0	Ground Millivolts, Gain 1
57	XXXXXGD1	Ground Millivolts, Gain 10
58	XXXXXGD2	Ground Millivolts, Gain 100
59	XXXXXGD3	Ground Millivolts, Gain 1000
60	XXXXX+5V	+5 System Millivolts
61	XXXXX-5V	-5 System Millivolts
62	XXXXX+LV	+Lamp Millivolts
63	XXXXX+8V	+8 System Millivolts
64	XXXXXA0	Calibration Coefficient A0
65	XXXXXB0	Calibration Coefficient B0
66	XXXXXB1	Calibration Coefficient B1
67	XXXXXC0	Calibration Coefficient C0
68	XXXXXC1	Calibration Coefficient C1
69	XXXXXC2	Calibration Coefficient C2
70	XXXXXD0	Calibration Coefficient D0
71	XXXXXD1	Calibration Coefficient D1
72	XXXXXD2	Calibration Coefficient D2
73	XXXXXD3	Calibration Coefficient D3
74	XXXXXF	Calibration Coefficient F
75	XXXXXG	Calibration Coefficient G

* Test results are displayed xxxxx Indicates a numeric result

SECTION 12, continued

12.3.2 Other Instrument Diagnostics

12.3.2.1 Display Segments and Icons

Determine the proper functioning of all display segments and icons by using diagnostic **22**. Press **SETUP**. Use the edit keys to change the large display to read **22**, and press **ENTER**. Press **UNITS/Exit** to stop the display test.

12.3.2.2 Cold Start

A cold start of the instrument erases from memory any calibration data entered by the user. The instrument must be recalibrated before use. Press and hold the **CAL/Zero** key, and then turn the instrument power on to place the instrument in a cold start condition. After cold start, the **CAL?** annunciator flashes until another calibration is entered. A minimum of the first four data points must be used (see *Section 3.2* on page 40).

12.3.2.3 Flashing 9s

If the display flashes all **9s**, the sample being measured is overrange (for the selected range of measurement). If the display flashes **9s** when the instrument is in the automatic range mode or the highest manual range, the sample is over the range of the instrument. The instrument also indicates overrange if the sample is > 40 NTU (268 Nephelos or 9.8 EBCs), and the instrument is in Ratio Off mode (refer to *Section 2.3.7* on page 30).

12.3.2.4 Flashing 0s

If the display flashes **0s**, the sample is under-range. When measuring Color, Absorbance or Transmittance, reestablish the analytical reference point and measure again. In addition, when measuring absorbance, make sure the reading is positive; to measure samples with negative absorbance, establish the analytical zero using the sample with the greatest absorbance, and read the sample with the least absorbance. Report the reading as negative absorbance.

SECTION 13

REPLACEMENT PARTS AND ACCESSORIES

Description	Cat. No.
2100AN Laboratory Turbidimeter (115/230V with UL and CSA approved power cord and fuse)	47001-00
2100AN Laboratory Turbidimeter (with European power cord and electrical fuse)	47001-02

Replacement Items

Cover, lamp compartment	47032-00
Cover, sample cell compartment	47713-00
Dust Cover.....	47030-00
Filter Assembly, USEPA Method 180.1.....	30312-00
Formazin Primary Turbidity Stock Solution, 4000 NTU, 100 mL	2461-42
Formazin High Range Turbidity Standard, 7500 NTU ampule	25842-02
Instrument Manual	47001-88
Lamp Kit, Replacement.....	47089-00
Oiling Cloth.....	47076-00
Power Cord, 18/3 SVT, 10 A, 125 V, (North American, 115 Vac, UL/CSA approved Power Cord)	18010-00
-OR-	
Power Cord, .75 mm SQX3 conductor, (European, 230 Vac, VDE approved Power Cord).....	46836-00
Printer Paper, pkg of 5.....	47090-00
Printer, access panel	47054-00
Sample Cells, 6/pkg.....	20849-00
Silicone Oil, 15 mL dropper bottle.....	1269-36
StableCal® Primary Standards in sealed vials	26595-05

Optional Reagents and Accessories

Bath, ultrasonic.....	24895-00
Cable, computer, DB-9 to DB-9.....	49502-00
Calibration Kit, StablCal® for 2100AN Turbidimeter	
<0.1-, 20-, 200-, 1000-, 4000-, and 7500-NTU, 500 mL each.....	26595-00
<0.1-, 20-, 200-, 1000-, 4000-, and 7500-NTU, ampules	26595-05
Cell Adapter, 12-13 mm	30334-00
Cell Adapter, 16 mm	30335-00
Cell Adapter, 19 mm	30336-00
Color Standard Solution 500 Platinum Cobalt Units, 1000 mL.....	1414-53
Filter, membrane (without pad), 200/pkg.....	13530-01
Filter Disks, 10/pk	23238-10
Filter Assembly Set	30397-00
Includes:	
410 nm Filter Assembly	30363-00
500 nm Filter Assembly	30367-00
560 nm Filter Assembly	30371-00
610 nm Filter Assembly	30373-00
810 nm Filter Assembly	30376-00
860 nm Filter Assembly	19999-00
Filter Paper, glass fiber, quantitative, 47 mm	2530-00
Flask, Erlenmeyer, 500 mL	505-49
Flow-Cell Kit, Automated, 115V	47450-00
Flow-Cell Kit, Automated, 230V	47450-02
Flow-Cell Kit, Manual	47449-00
Flow-Cell Kit, High-Pressure.....	47451-00
Flow Valve Module with 120 Vac power supply (included with Automated Flow-Cell Kit)	47445-00
Flow Valve Module with 220 Vac power supply (included with Automated Flow-Cell Kit)	47445-02

SECTION 13, continued

Optional Reagents and Accessories, continued

Description	Cat. No.
Formazin Primary Turbidity Stock Solution, 4000 NTU, 500 mL.....	2461-49
Fuse for 115V operation, 250V, 1.6A, UL/CSA approved.....	30307-00
Fuse for 230V operation, 250V, 1.6A, IEC type, VDE approved.....	30306-00
Hexamethylenetetramine, 100 g.....	1878-26
Hexamethylenetetramine, 500 g.....	1878-34
Hydrazine Sulfate, 100 g.....	742-26
Power Supply, Flow Valve Module, 12 Vdc, 110 Vac (included with Automated Flow-Cell Kit).....	47469-00
Power Supply, Flow Valve Module, 12 Vdc, 220 Vac (included with Automated Flow-Cell Kit).....	47470-00
Pump, vacuum, hand-operated.....	14283-00
Pump, vacuum/pressure, portable, 115V, 60 Hz, 1.3 cfm.....	14697-00
Pump, vacuum/pressure, portable, 220V, 50 Hz, 1.3 cfm.....	14697-02
Ribbon Cartridge, iDP-562 (for Citizen Printer Model iDP-562).....	25934-00
Sample Degassing Kit.....	43975-00
Sample Degassing and Filtration Kit.....	43975-10
Surfactant, Triton X-100, 100 mL.....	14096-32
TenSette [®] Pipet, 1-10 mL, for calibration dilutions.....	19700-10
TenSette [®] Pipet Tips, 1-10 mL, pk/50.....	25597-10
Tubing, 1/4-inch OD plastic, for High-Pressure Flow Cell.....	42152-00
Ultrasonic Bath, Branson [®]	24895-00
Volumetric Flask, 100 mL, for calibration dilutions.....	14574-42
Volumetric Flask, 200 mL, for calibration dilutions.....	14574-45
Volumetric Flask, 1000 mL.....	547-53
Water, Deionized, 4L.....	272-56



GENERAL INFORMATION

At Hach Company, customer service is an important part of every product we make.

With that in mind, we have compiled the following information for your convenience.

How To Order

By Telephone:

6:30 a.m. to 5:00 p.m. MST
Monday through Friday
(800) 227-HACH
(800-227-4224)

By FAX: (970) 669-2932

By Mail:

Hach Company
P.O. Box 389
Loveland, CO 80539-0389
U.S.A.

Ordering information by E-mail: orders@hach.com

Information Required

- Hach account number (if available)
- Your name and phone number
- Purchase order number
- Brief description or model number
- Billing address
- Shipping address
- Catalog number
- Quantity

Technical and Customer Service (U.S.A. only)

Hach Technical and Customer Service Department personnel are eager to answer questions about our products and their use. Specialists in analytical methods, they are happy to put their talents to work for you.

Call **1-800-227-4224** or E-mail **techhelp@hach.com**.

International Customers

Hach maintains a worldwide network of dealers and distributors. To locate the representative nearest you, send E-mail to **intl@hach.com** or contact:

In Canada, Latin America, Africa, Asia, Pacific Rim:

Telephone: (970) 669-3050; FAX: (970) 669-2932

In Europe, the Middle East, or Mediterranean Africa:

HACH Company, c/o

Dr. Bruno Lange GmbH

Willstätterstr. 11

D-40549 Düsseldorf

Germany

Telephone: +49/[0]211.52.88.0

Fax: +49/[0]211.52.88.231

Repair Service

Authorization must be obtained from Hach Company before sending any items for repair. Please contact the HACH Service Center serving your location.

In the United States:

Hach Company
100 Dayton Avenue
Ames, Iowa 50010
(800) 227-4224 (U.S.A. only)
Telephone: (515) 232-2533
FAX: (515) 232-1276

In Canada:

Hach Sales & Service Canada Ltd.
1313 Border Street, Unit 34
Winnipeg, Manitoba
R3H 0X4
(800) 665-7635 (Canada only)
Telephone: (204) 632-5598
FAX: (204) 694-5134
E-mail: canada@hach.com

**In Latin America, the Caribbean, the Far East, the
Indian Subcontinent, Africa, Europe, or the Middle East:**

Hach Company World Headquarters
P.O. Box 389
Loveland, Colorado, 80539-0389
U.S.A.
Telephone: (970) 669-3050
FAX: (970) 669-2932
E-mail: intl@hach.com

Warranty

Hach warrants most products against defective materials or workmanship for at least one year from the date of shipment; longer warranties may apply to some items.

HACH WARRANTS TO THE ORIGINAL BUYER THAT HACH PRODUCTS WILL CONFORM TO ANY EXPRESS WRITTEN WARRANTY GIVEN BY HACH TO THE BUYER. EXCEPT AS EXPRESSLY SET FORTH IN THE PRECEDING SENTENCE, HACH MAKES NO WARRANTY OF ANY KIND WHATSOEVER WITH RESPECT TO ANY PRODUCTS. HACH EXPRESSLY DISCLAIMS ANY WARRANTIES IMPLIED BY LAW, INCLUDING BUT NOT BINDING TO ANY WARRANTY OF MERCHANTABILITY OR FITNESS FOR A PARTICULAR PURPOSE.

LIMITATION OF REMEDIES: Hach shall, at its option, replace or repair nonconforming products or refund all amounts paid by the buyer. **THIS IS THE EXCLUSIVE REMEDY FOR ANY BREACH OF WARRANTY.**

LIMITATION OF DAMAGES: IN NO EVENT SHALL HACH BE LIABLE FOR ANY INCIDENTAL OR CONSEQUENTIAL DAMAGES OF ANY KIND FOR BREACH OF ANY WARRANTY, NEGLIGENCE, ON THE BASIS OF STRICT LIABILITY, OR OTHERWISE.

This warranty applies only to Hach products purchased and delivered in the United States.

Catalog descriptions, pictures and specification, although accurate to the best of our knowledge, are not a guarantee or warranty.

For a complete description of Hach Company's warranty policy, request a copy of our Terms and Conditions of Sale for U.S. Sales from our Customer Service Department.

