

Microprocessor controlled system for the determination and control of hydrazine or carbohydrazide used as boiler feedwater oxygen scavengers

Monitor AMI Hydrazine

Complete system on stainless steel mounting panel:

- **Transmitter AMI Hydrazine**
in a rugged aluminum enclosure (IP 66).
- **Sensor system**
Self-cleaning three-electrode system for determination of hydrazine or carbohydrazide.
- **Flow cell**
made of acrylic glass with flow adjustment valve, digital sample flow monitor and integrated temperature probe. Sample alkalization with highly efficient diisopropylamine
- Factory tested, ready for installation and operation.

Specifications:

- Measurement range for hydrazine or carbohydrazide: 0.1 to 600 ppb
- Automatic temperature compensation.
- Automatic, continuous monitoring of sample flow and sensor cleanliness.
- Big backlit LC display for the reading of measuring value, sample temperature, sample flow and operating status.
- Easy user menus in English, German, French and Spanish. Simple programming of all parameters by keypad.
- Electronic record of major process events and calibration data.
- Data logger for 1'500 data records stored at a selectable interval. (Data download to PC requires optional HyperTerminal interface).
- Two current signal outputs (0/4 - 20 mA), galvanically separated from sensor input, for hydrazine or carbohydrazide concentration and temperature or as continuous control outputs.

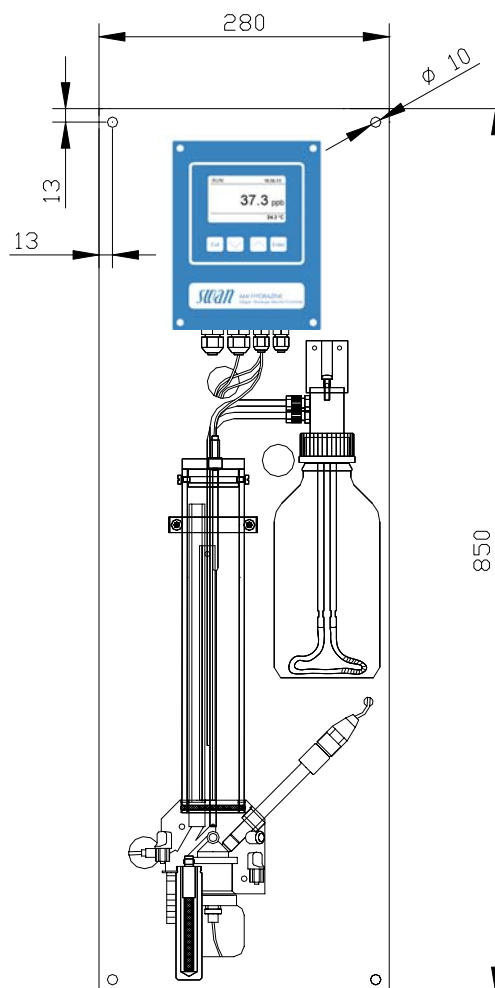

Order scheme	Monitor AMI Hydrazine	A - 26.54	.	0		0
Power supply	85-265 VAC, 47-63 Hz	1	↑			
	24 VDC, direct current.....	2	↑			
Signal output option	None					0
	Third current signal output 0/4 - 20 mA					1
	Profibus DP interface					2
	HyperTerminal interface (for logger download)					3
	Modbus interface (required for <i>Webserver</i>)					4

Hydrazine / Carbohydrazide Measurement

Self-cleaning three-electrode system with automatic temperature compensation. Maintenance-free reference electrode.

Range: 0.1 - 600 ppb

Accuracy: 5% of reading up to 200 ppb
± 15% up to 600 ppb
or ± 2 ppb

Stability: ± 5% of reading per month
or ± 2 ppb per month

Response time: 90 % of change
60 sec after sample entered flow cell

Temperature measurement NT5K

Measuring range: up to 60 °C
Resolution: 0.1 °C

Sample flow measurement

With digital SWAN sample flow meter and alarm in case of insufficient sample flow.

Transmitter Specifications and Functionality

Electronics case: Cast aluminum
Protection degree: IP 66 / NEMA 4X
Display: backlit LCD, 75 x 45 mm
Electrical connectors: screw clamps
Dimensions: 180 x 140 x 70 mm
Weight: 1.5 kg
Ambient temperature: -10 to +50°C
Humidity: 10 - 90% rel., non condensing

Power supply

Voltage: 85 - 265 VAC, 47 - 63 Hz
or 24 VDC, ± 15 %
Power consumption: max. 20 VA

Operation

Easy operation based on separate menus for "Messages", "Diagnostics", "Maintenance", "Operation" and "Installation". User menus in English, German, French and Spanish.

Separate menu specific password protection.

Display of process value, sample flow, alarm status and time during operation. Storage of event log, alarm log and calibration history.

Storage of the last 1'500 data records in logger with selectable time interval.

Safety features

No data loss after power failure, all data is saved in non-volatile memory.

Overvoltage protection of in- and outputs.

Galvanic separation of measuring inputs and signal outputs.

Electrical Connection Scheme

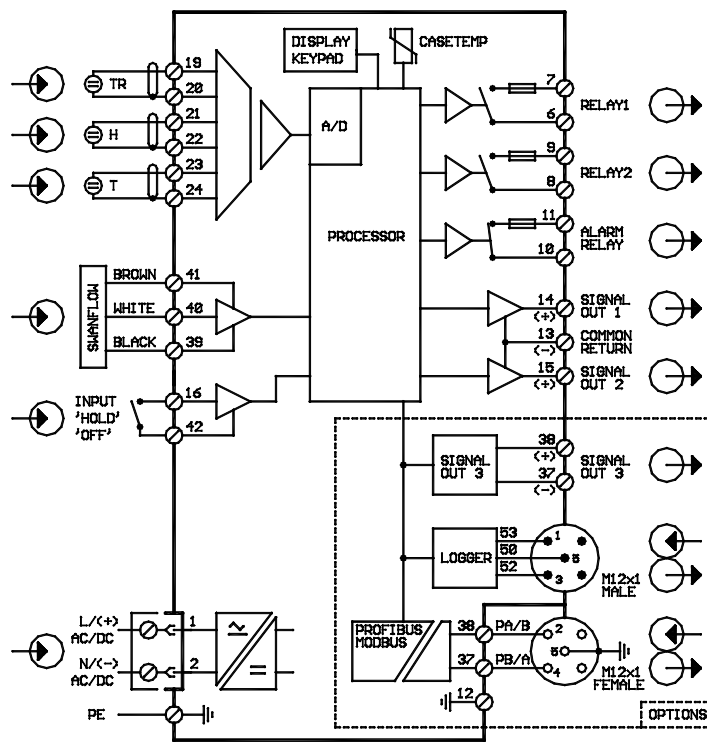

Transmitter temperature monitoring with programmable high/low alarm limits.

1 Alarm relay

One potential free contact for summary alarm indication for programmable alarm values and instrument faults.
Maximum load: 1A / 250 VAC

1 Input

One input for potential-free contact. Programmable hold or remote off function.

2 Relay outputs

Two potential-free contacts programmable as limit switches for measuring values, controllers or timer for system cleaning with automatic hold function.
Rated load: 1A / 250 VAC

2 Signal outputs (3rd as option)

Two programmable signal outputs for measured values (freely scaleable, linear or bilinear) or as continuous control outputs (control parameters programmable).
Current loop: 0/4 - 20 mA
Maximum burden: 510 Ω

Control functions

Relays or current outputs programmable for 1 or 2 pulse dosing pumps, solenoid valves or for one motor valve. Programmable P, PI, PID or PD control parameters.

1 Communication interface (option)

RS232 interface for logger download to PC with Microsoft HyperTerminal or RS485 interface (galvanically separated) with Fieldbus protocol Modbus or Profibus DP.

Monitor Data

Sample conditions

Flow rate: approx. 15 L/h
Temperature range: 15 - 45 °C
Inlet pressure: 0.15 - 2 bar
Outlet pressure: pressure free
pH value: equal or higher than pH 7.0
Reagent consumption (at 25°C): < 1L diisopropylamine per month

Flow cell and connections

Acrylic glass with safety filter, metering tap and sample tap, inserts for all sensors.

Sample inlet: tube adapter 4 x 6 mm
Sample outlet: tube adapter 15 x 20 mm

Panel

Dimensions: 850 x 280 x 200 mm
Material: stainless steel
Total weight: 9.0 kg