

Electronic transmitter & controller for the measurement of specific conductivity, concentration, salinity and TDS.

Transmitter AMI Inducon

- Measuring and control transmitter in rugged aluminum enclosure (IP 66).
- Wide conductivity measurement range from 0 to 2000 mS/cm.
- For the measurement of specific conductivity, concentrations (for NaCl, NaOH and acids in %), salinity (as NaCl in %) and total dissolved solids (TDS as NaCl in %).
- Connections for an inductive (toroidal) conductivity sensor with built-in Pt1000 temperature probe (Swansensor Inducon1000) and for a digital SWAN sample flow meter.
- Temperature compensation with selectable coefficient or non-linear function for natural waters according to EN 27888.
- Easy user menus in English, German, French and Spanish. Simple programming of all parameters by keypad.
- Electronic record of major process events and calibration data.
- Real-time clock for time stamp in data logs and for automated functions.
- Data logger for 1'500 data records stored at a selectable interval. (Data download to PC requires optional HyperTerminal interface).
- Big backlit LC display for the reading of measuring value, sample temperature, sample flow, temperature compensation type, substance name (for concentration measurements) and operating status.
- Galvanically separated sensor connection.
- Overvoltage protection for in- and outputs.
- Two current outputs (0/4 - 20 mA) for measured signals.

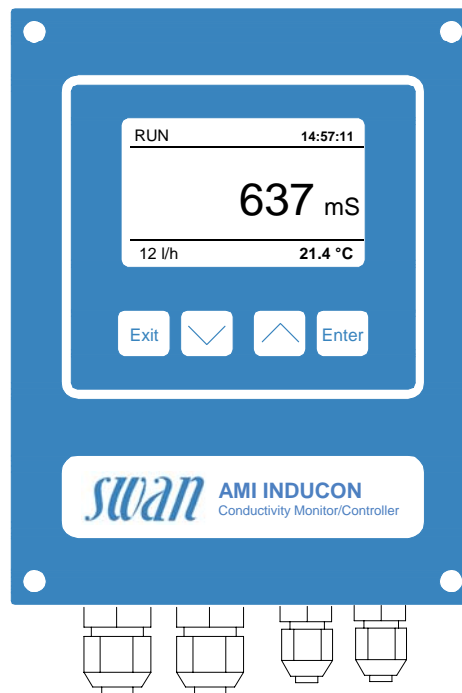

- Potential-free alarm contact as summary alarm indication for programmable alarm values and for instrument faults.
- Two potential-free contacts programmable as limit switch or PID-control.
- Input for potential-free contact to freeze the measuring value or to interrupt control in automated installations (hold function or remote-off).

Order scheme	Transmitter AMI Inducon	A	1	3	.	4	3	1	.	X	0	X
Power supply	85 - 265 VAC / 47 - 63 Hz									1		
	24 VDC, direct current									2		
Electrical output option	None											0
	Third current signal output 0/4 - 20 mA											1
	Profibus DP interface											2
	HyperTerminal interface (for logger download)											3
	Modbus interface (for <i>Webs</i> erver connection)											4

Conductivity Measurement

Conductivity type sensor

Inductive (toroidal) sensor: Swansensor Inducon1000.

Conductivity ranges	Resolution
0.00 to 9.99 mS/cm	0.01 mS/cm
10.0 to 99.9 mS/cm	0.1 mS/cm
100 to 2'000 mS/cm	1 mS/cm

Measurement error < 1 %

Temperature compensations

- Absolute (none)
- Linear coefficient (0.00 - 19.99 %/°C)
- Non linear function (NLF) for natural waters according to EN 27888

Concentration measurements

- NaCl: 0 to max. 17.9 - 21 % (0 - 50°C)
- HCl: 0 to max. 10 - 12 % (0 - 50°C)
- NaOH: 0 to max. 6.5 - 9 % (0 - 50°C)
- H₂SO₄: 0 to max. 16 - 22 % (0 - 50°C)
- HNO₃: 0 to max. 17 - 20.8 % (0 - 50°C)
- Salinity (as NaCl) in %
- TDS (Total Dissolved Solids as NaCl) in %

Temperature measurement

with Pt1000 type sensor (DIN class A)
Measuring range: -30 to +250 °C
Resolution: 0.1 °C

Transmitter Specifications and Functionality

Electronics case: Cast aluminum
Protection degree: IP 66 / NEMA 4X
Display: backlit LCD, 75 x 45 mm
Electrical connectors: screw clamps
Dimensions: 180 x 140 x 70 mm
Weight: 1.5 kg
Ambient temperature: -10 to +50°C
Humidity: 10 - 90 % rel., non condensing

Power supply

Voltage: 85 - 265 VAC, 47 - 63 Hz
or 24 VDC, ± 15 %
Power consumption: max. 20 VA

Operation

Easy operation based on separate menus for "Messages", "Diagnostics", "Maintenance", "Operation" and "Installation".

User menus in English, German, French and Spanish.

Separate menu specific password protection.

Electrical Connection Scheme

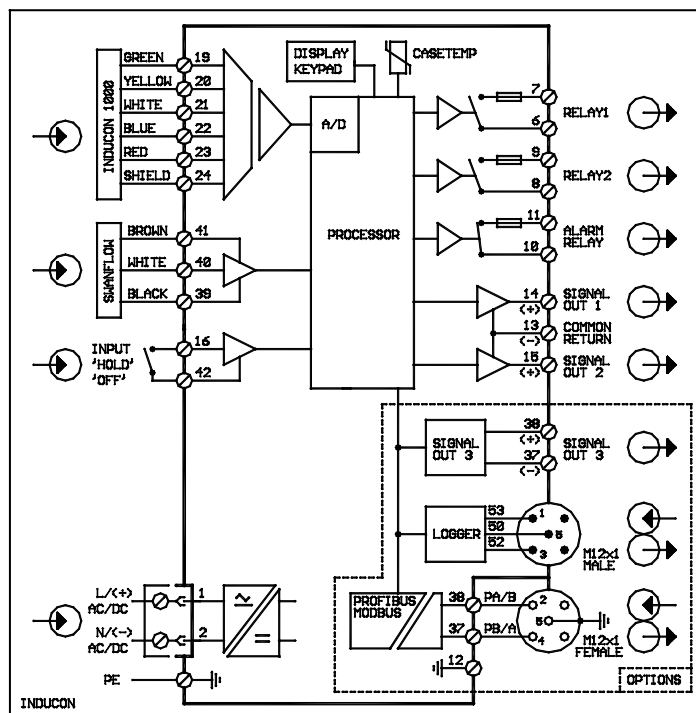

Display of process value, sample flow, alarm status and time during operation.

Storage of event log, alarm log and calibration history.

Storage of the last 1'500 data records in logger with selectable time interval.

Real-time clock with calendar

For action time stamp and preprogrammed actions.

Safety features

No data loss after power failure, all data is saved in non-volatile memory.
Overvoltage protection of in- and outputs.
Galvanic separation of measuring inputs and signal outputs.

Transmitter temperature monitoring
with programmable high/low alarm limits.

1 Alarm relay

One potential free contact for summary alarm indication for programmable alarm values and instrument faults.
Maximum load: 1A / 250 VAC

1 Input

One input for potential-free contact.
Programmable hold or remote off function.

2 Relay outputs

Two potential-free contacts programmable as limit switches for measuring values, controllers or timer for system cleaning with automatic hold function.
Max. load: 1A / 250 VAC

2 Signal outputs (3rd optional)

Two programmable signal outputs for measured values (freely scaleable, linear or bilinear) or as continuous control outputs (control parameters programmable).
Current loop: 0/4 - 20 mA
Maximum burden: 510 Ω

Control functions

Relays or current outputs programmable for 1 or 2 pulse dosing pumps, solenoid valves or for one motor valve.
Programmable P, PI, PID or PD control parameters.

1 Communication interface (option)

RS232 interface for logger download to PC with Microsoft HyperTerminal or RS485 interface (galvanically separated) with Fieldbus protocol Modbus or Profibus DP.

Remote instrument access with PC requires Modbus interface and optional Webserver.