



The guarantee of your protection will be only ensured after the erlab® laboratory approval. Please contact your supplier and benefit from the ESP® (Erlab Safety Program) for a validation of the safety parameters (type of column, filter lifetime, saturation detection method and replacement filter procedure...), linked to the use of this cabinet.

Technical specifications

Dimensions (mm)						
Ref.	External dimensions			Internal dimensions - without work surface		
	Width	Depth	Height*	Width	Depth	Height
XLS 714	1800	800	1315 mini 1495 maxi	1765	695	1040

*According to filtration column type

Structure	
Metallic parts	Anti-corrosion metallic alloy protected by a thermo-hardened anti-acid polymer coating
Side and front panels	6 mm thick acrylic
Filtration module	Polypropylene

Specifications	
Number of columns	4
Number of fans (IP44)	4
Processed air flow	920 m³/h
Air velocity at the openings in working position	0,4 to 0,6 m/s
Voltage / Frequency	90 - 264 V / 50 Hz
Total power consumption including electricity for the lights	76-194 Watts
Amperage absorbed	6,4 amp.

Modular filtration column	
Type IP Powders handlings	

Modular filtration column			
Class 2 - (NFX 15-211 : 2009 standard)		Class 1 - (NFX 15-211 : 2009 standard)	
Type IC Liquid chemicals handlings		Type 2C Liquid chemicals handlings	
Type IP IC Liquid chemicals and powders handlings		Type IP 2C Liquid chemicals and powders handlings	
Type IC IP Liquid chemicals and powders handlings in clean room		Type 2C IP Liquid chemicals and powders handlings in clean room	

Molecular filter H14 HEPA filter

Equipments

Standard Equipment		Options	
Air flow meter	Permanent air face velocity monitoring system	Molecode S*	Automatic alarm to detect filter saturation by solvents according to NF X 15 211 : 2009 standard (*compulsory for class 1 configuration)
Flow monitor	Permanent ventilation control device according to EN 14175-2:2003 standard	Work surface N°1	Tempered glass work surface with seeled frame
Internal lighting	Compact tubular fluorescent lighting - 18 Watts - 500 Lux - IP 67	Work surface N°2	In phenolic resin with built-in retention tray
Sampling port	For filter saturation detection (N/A if Molecode S installed)	Benchcap	Fixed work bench made of anti-corrosion metallic alloy
Programmable timer	Timer - 60 hours setting by default according to NFX 15 211: 2009 standard	Shelf	Adjustable sliding shelf for Mobicap and Benchcap
Energy ports	For the passage of cables	Transparent back panel	Acrylic
Chemical Listing	List of approved chemicals	Access door on rear panel	For maintenance interventions
		Particular Pre-filter	40 % filtration efficiency for particles > 0,3 µm

Types of filters available

GF4 AS	For organic vapours
GF4 BE +	For organic vapours + acid vapours
GF4 F	For formaldehyde vapours
GF4 K	For ammonia vapours
GF4 HP	H14 HEPA Filter for powders

Compliance to standards

- AFNOR NF X 15-211:2009 - France
- ANSI/ASHRAE 110-1995 - USA
- BS 7258 - England
- CSA Z316.5 - Canada
- CE Marking
- NF P92.507 (Acrylic part)
- EN 1822 : 1998 (H14 HEPA filter)

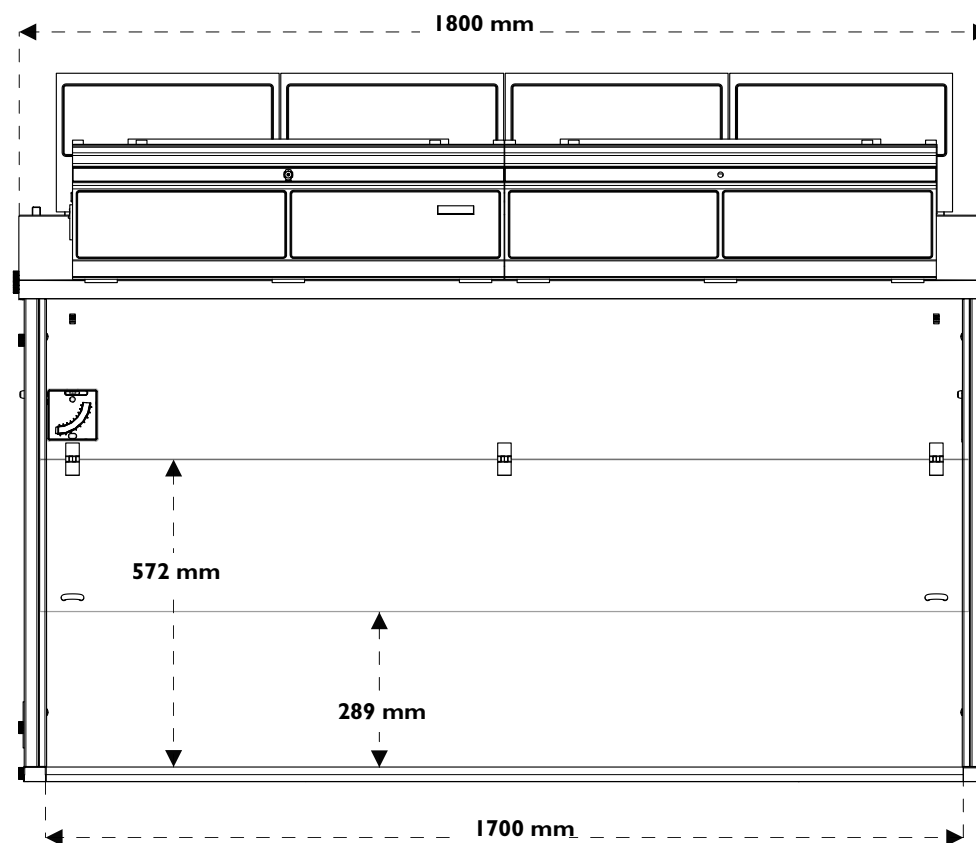
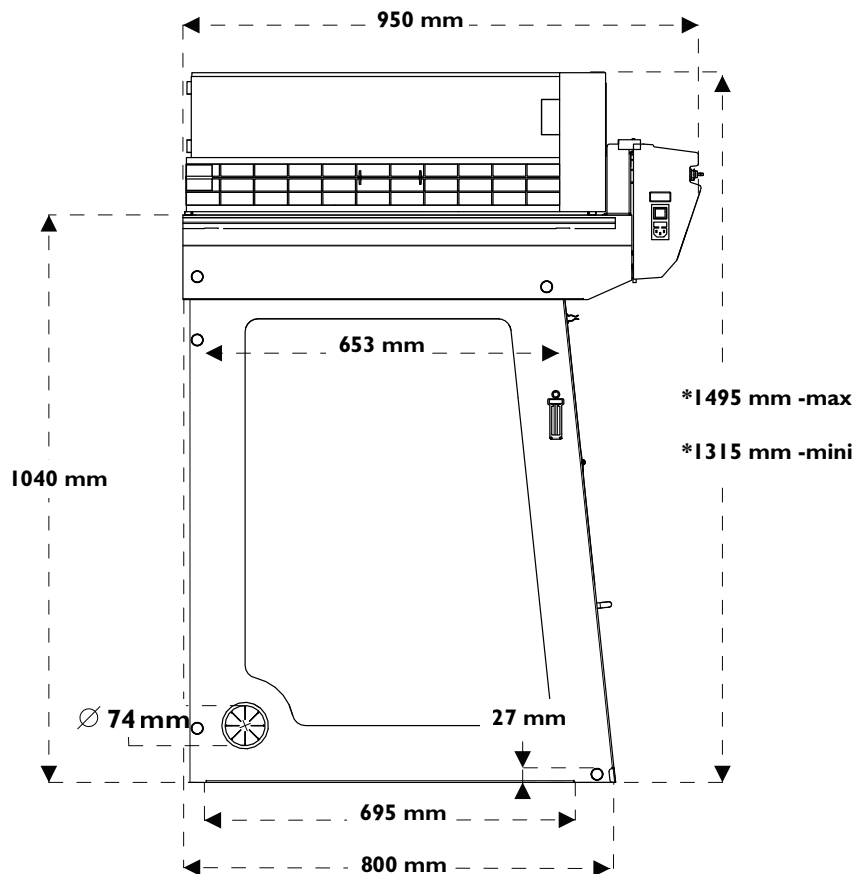

*Total height according to filtration column type (mm)			
Type IP	1315	Type 2C	1406
Type IC	1315	Type IP 2C	1495
Type IP IC	1406	Type 2C IP	1495
Type IC IP	1406		



Work surface N°1

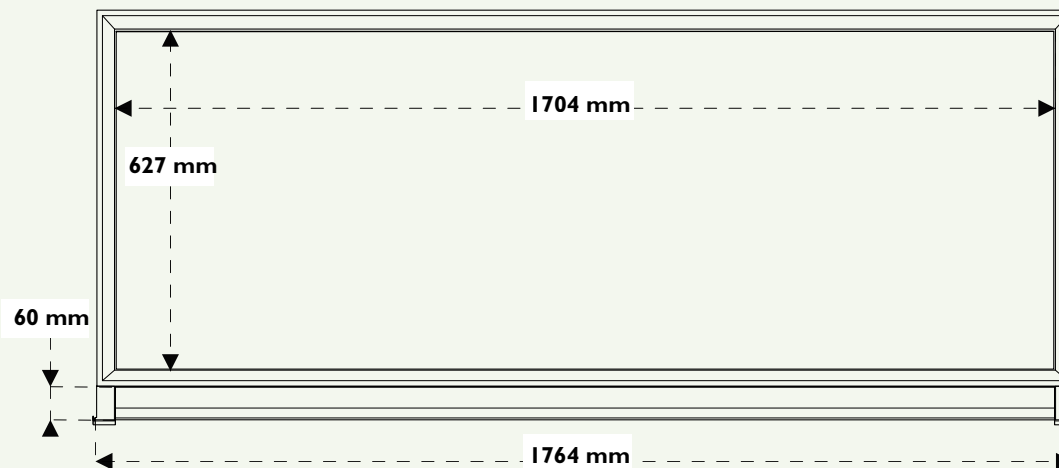

Work surface N°2

