

Technical specifications GFH 4200



Green Fume Hood 4200

Structure	Metallic parts	Electrogalvanized steel sheet - anti acid polyester coating
	Front Sash	Laminated glass
	Side panels	Laminated glass
	Control panel	Polypropylene (PP) - Acrylonitrile Butadiene Styrene (ABS)
	Work surface	Phenolic resin
Technical specifications	Processed air flow	between 440 and 460 m ³ /h
	Average air face velocity	between 0,4 and 0,6 m/s
	Working sash height	34cm at 0.5 m/s 66 cm at maximum working sash height
	Fan electrical protection rating	IP44
	Voltage	100 - 240 v
	Frequency	50 - 60 Hz
	Total power consumption	5A max
	Noise level	67 dbA at 4600 t/m
	HEPA filter	HEPA H14 - 99,995% filtration efficiency (according to EN-1822 - MPPS test)
	Molecular filter	Neutrodine® - discharge inferior to 1% of the TLV (according to NF X 15-211 : 2009 standard)
	Pre-filter	Electrostatic filtering media
	Weight	145 kg
	Enclosure air renewal	528 times/hour

Standards

Compliant with the AFNOR NFX 15-211 : 2009 standard requirements
Containment tested according to ANSI / ASHRAE 110-1995 - EN 14 175 standards
CE marking

Standard equipment	Master module	1
	Number of modular filtration columns	2
	Number of main filters	B - Liquid chemistry : 2 G - Clean room : 2 D - Liquid chemistry and powders : 2
	Number of safety back up filters	B - Liquid chemistry : 2 G - Clean room : 2 D - Liquid chemistry and powders : 2
	Number of HEPA Filter	B - Liquid chemistry : 0 G - Clean room : 2 D - Liquid chemistry and powders : 2
	Number of pre-filters	2
	Number of fans	2
	Temperature sensor	Control range: -15 to 120° C Alarms at 60 and 80°C
	Sash position detection system	from 15 to 66 cm
	Lighting	type 2 G11 - IP68 Compact fluorescent tubes x 2 1x18 Watt (1 tube per module) - ≥ 500 lux
	Embedded electronic system	ARM 9 Motherboard - 16 Mo cache Windows CE 5.0
	Ethernet port	1 RJ45 port

Optional equipments	gGuard™	Remote monitoring software
	gStation	Fixed work bench
	Molecode A (acids)	Electrolytic cell
	Electrical equipments adapter	Standard 45x45 diam. 22 or 27 mm for direct taps or remote control
	Taps adapter	
	Mounting racks supports	Aluminium diam. 16 mm

Green Fume Hood 4200

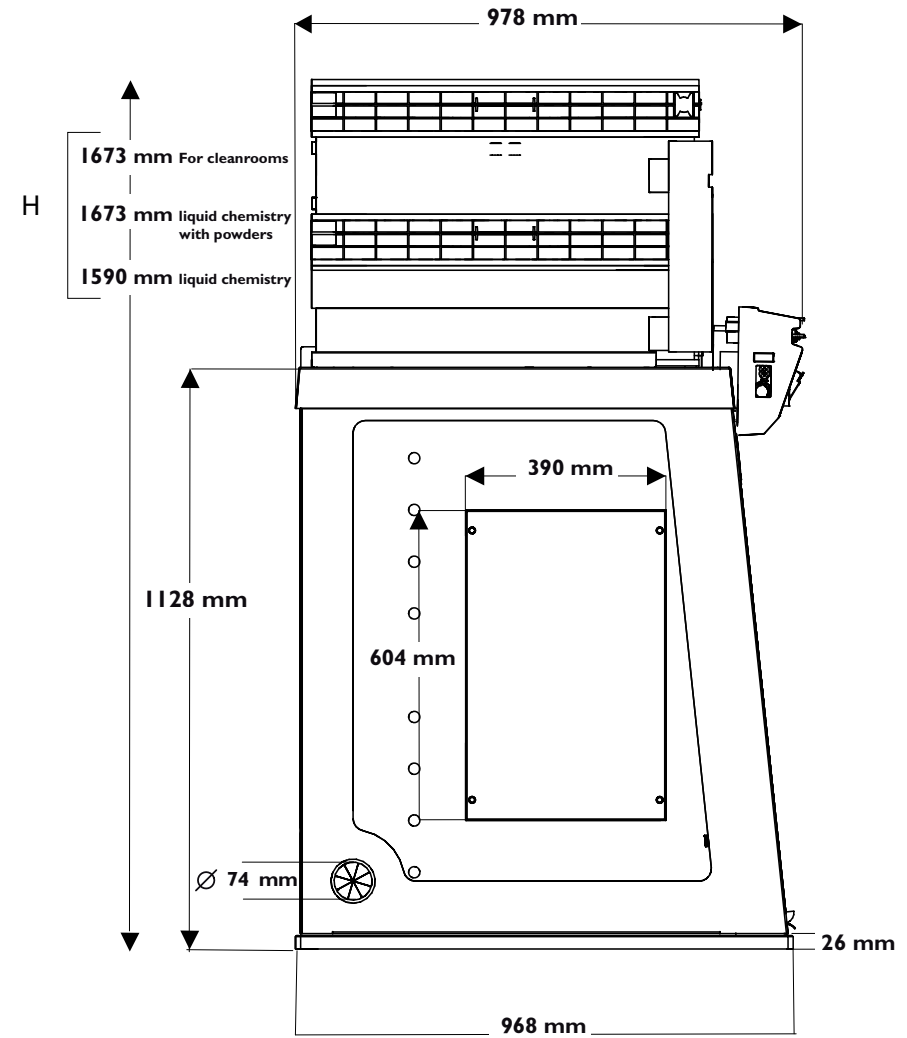
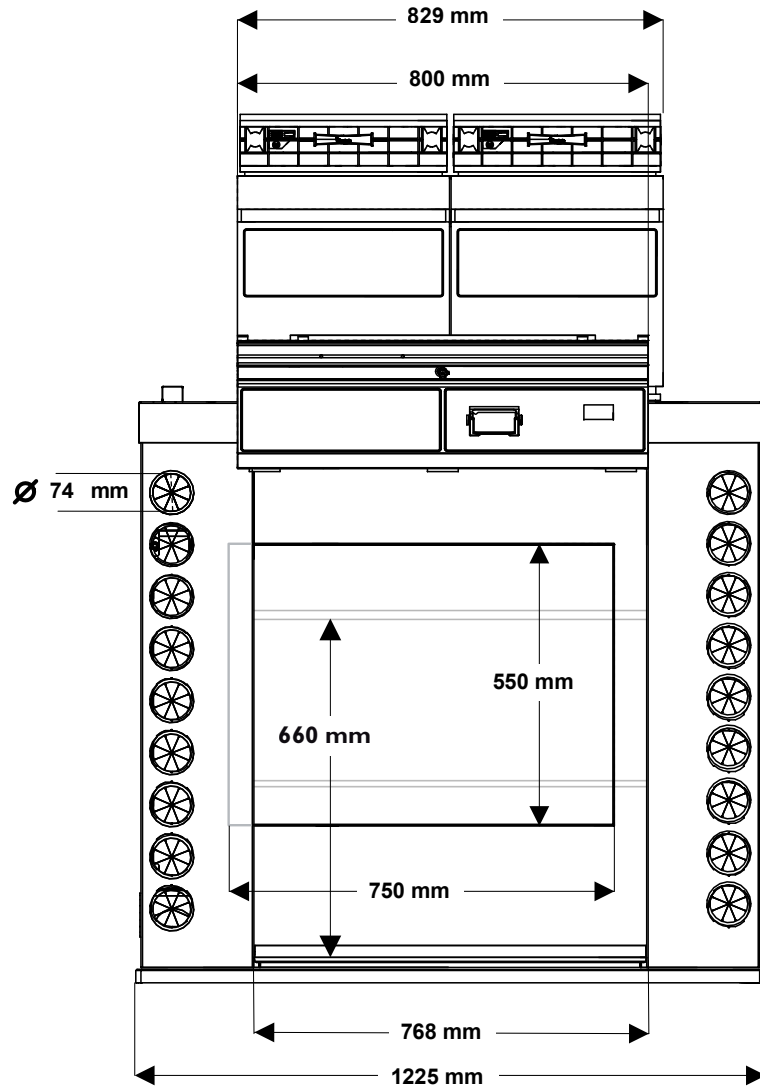

Green Fume Hood 4200

Filtration columns types

B For liquid chemistry

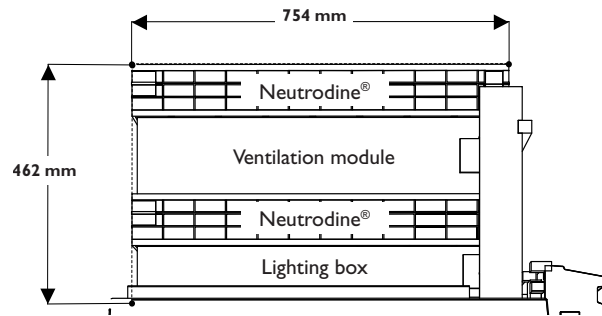

D For liquid chemistry with powders

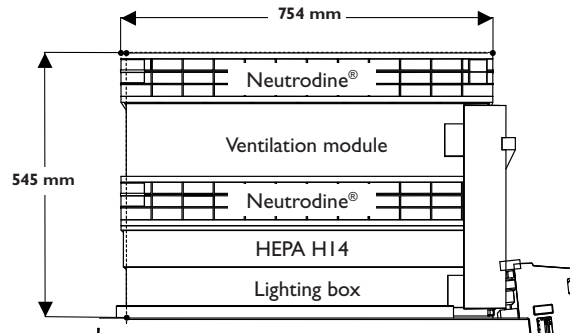

G For cleanrooms

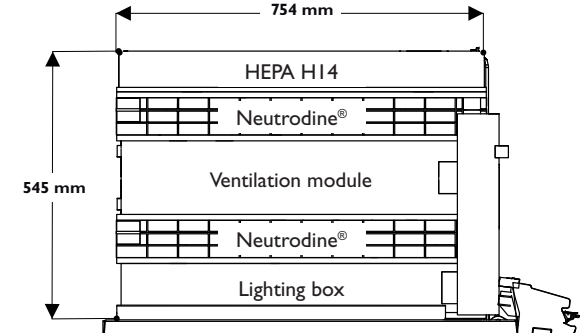

Work surface

