



## Incubator IF75plus

The incubator I is at home everywhere in the world of research, medicine, pharmaceuticals and food analytics, as well as food chemistry.



The heating of this incubator is optimally tuned for both natural convection and forced air circulation; the fan can also be switched off completely, and valuable chamber loads for research, pharmaceuticals, medicine and food chemistry are warmed up very carefully.

On this page, you can find all the essential technical data on our incubator. Our customer relations team will be pleased to help if you want further information. If you should require a customised special solution, please contact our technical specialists at [myAtmoSAFE@memmert.com](mailto:myAtmoSAFE@memmert.com).

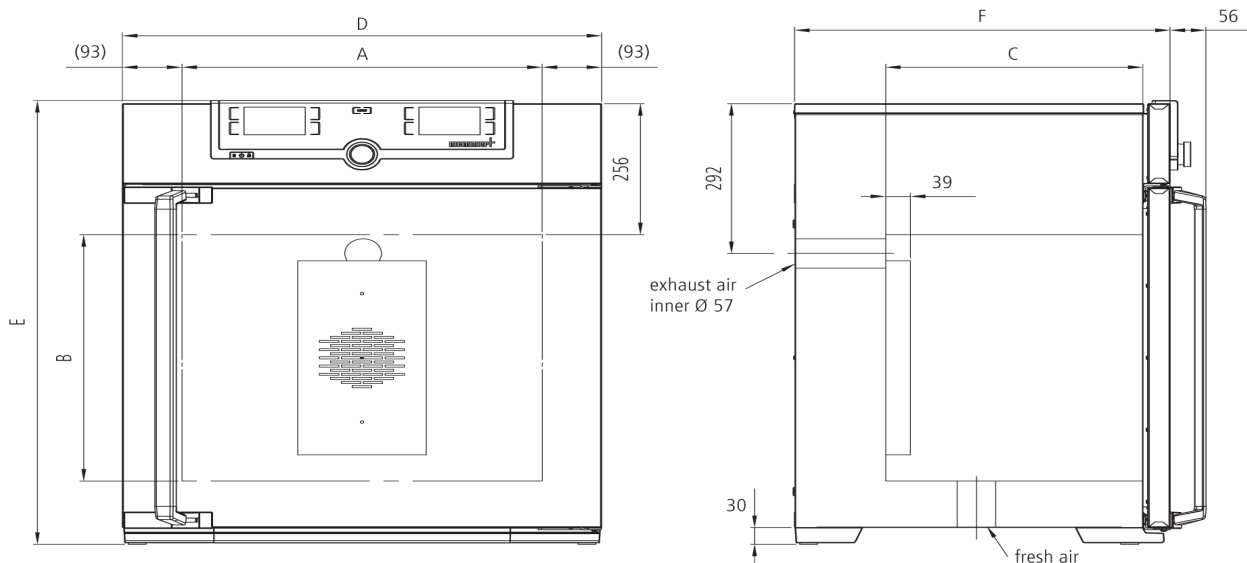

## Temperature

**Working temperature range** min. 10°C above ambient up to +80°C

**Setting accuracy temperature** 0.1°C

**Temperature** 2 Pt100 sensors Class A in 4-wire-circuit, mutually monitoring and taking over the performance at the same temperature value

## Control technology

**ControlCOCKPIT** TwinDISPLAY. Adaptive multifunctional digital PID-microprocessor controller with 2 high-definition TFT-colour displays.

**Language setting** German, English, Spanish, French, Polish, Czech, Hungarian

**Timer** Digital backwards counter with target time setting, adjustable from 1 minute to 99 days

**Function HeatBALANCE** adapting the distribution of the heating performance of the upper and lower heating circuit from -50 % to +50 %

**Function SetpointWAIT** the process time does not start until the set temperature is reached

**Calibration** three freely selectable temperature values

**adjustable parameters** temperature (Celsius or Fahrenheit), fan speed, air flap position, programme time, time zones, summertime/wintertime

**Sterilisation** fixed sterilisation programme (4 hours/160°C) for sterilisation of working chamber, not for sterilising the load

## Ventilation

**Fan** forced air circulation by quiet air turbine, adjustable in 10 % steps for each segment individually

**Fresh air admixture** adjustment of pre-heated fresh air admixture by air flap control in 10 % steps for each segment individually

**Vent** vent connection with restrictor flap

## Communication

**Documentation** programme stored in case of power failure

**Programming** AtmoCONTROL software on a USB stick for programming, managing and transferring programmes via Ethernet interface or USB port

## Safety

**Temperature control** mechanical temperature limiter TB, protection class 1 according to DIN 12880 to switch off the heating approx. 20°C above nominal temperature

**Temperature control** overtemperature monitor TWW, protection class 3.1 or adjustable temperature limiter TWB, protection class 2, selectable on display

**AutoSAFETY** additionally integrated over- and undertemperature monitor "ASF", automatically following the setpoint value at a preset tolerance range, alarm in case of over- or undertemperature, heating is switched off in case of overtemperature

**Autodiagnostic system** for fault analysis

**Alarm** visual and acoustic

## Standard equipment

|                                      |   |
|--------------------------------------|---|
| <b>Works calibration certificate</b> | incl. works calibration certificate for +37°C                                     |
| <b>Door</b>                          | fully insulated stainless steel door with 2-point locking (compression door lock) |
| <b>Door</b>                          | inner glass door  |
| <b>Internals</b>                     | 2 stainless steel grids   |

## Stainless steel interior

|                                     |  |
|-------------------------------------|--|
| <b>Interior</b>                     | easy-to-clean interior, made of stainless steel, reinforced by deep drawn ribbing with integrated and protected large-area heating on four sides |
| <b>Volume</b>                       | 74 l   |
| <b>Dimensions W x H x D in mm</b>   | $w_{(A)} \times h_{(B)} \times d_{(C)}$ : 400 x 560 x 330 mm   |
| <b>Max. number of grids/shelves</b> | 6  |
| <b>Max. loading of chamber</b>      | 120 kg   |
| <b>Max. loading per grid/shelf</b>  | 20 kg  |

## Textured stainless steel casing

|                   |  |
|-------------------|--|
| <b>Dimensions</b> | $w_{(D)} \times h_{(E)} \times d_{(F)}$ : 585 x 944 x 514 mm |
| <b>Housing</b>    | rear zinc-plated steel                                       |

## Electrical data

|                        |                 |
|------------------------|-----------------|
| <b>Voltage</b>         | 230 V, 50/60 Hz |
| <b>Electrical load</b> | approx. 1250 W  |
| <b>Voltage</b>         | 115 V, 50/60 Hz |
| <b>Electrical load</b> | approx. 900 W   |

## Packing/shipping data

**the appliances must be transported upright**

|                                       |                                |
|---------------------------------------|--------------------------------|
| <b>Customs tariff number</b>          | 8419 8998                      |
| <b>Country of origin</b>              | Federal Republic of Germany    |
| <b>WEEE-Reg.-No.</b>                  | DE 66812464                    |
| <b>Dimensions approx incl. carton</b> | B x H x T: 730 x 1130 x 670 mm |
| <b>Net weight</b>                     | approx. 66 kg                  |
| <b>Gross weight carton</b>            | approx. 85 kg                  |

**Standard units are safety-approved and bear the test marks**

