

## Constant climate chambers **HPP**



*Tailor-made for ongoing stability testing in pharmaceuticals*

*Innovative Peltier technology saves up to 90% of energy in comparison to compressor cooling*

*Active humidification and dehumidification for control range between 10% and 90% relative humidity*

**Seamless provisions**

**Applied climate protection**

**Fit for Arctics and Tropics**

>>>> [www.memmert.com](http://www.memmert.com)





Inner chamber made exclusively of high-grade fully recyclable stainless steel 1.4301 (ASTM 304). Exceptionally smooth and hygienic surfaces help to simplify spotless cleaning.

### **Stainless steel – high-grade material**

Functional design in its most elegant form: scratch-resistant, robust and durable. Over many years of practical application, high-grade stainless steel has proved to be superior to coated sheet steel, which can corrode rapidly during extended use.

## **Best climate for quality, environment and your budget!**

Reliable material tests are crucial for a constantly high product quality in research and development as well as industry. The high precision temperature control from 5 °C to 70 °C, as well as active humidification and dehumidification from 10% to 90% rh in the new HPP constant climate chambers, are optimally tuned to the requirements for ongoing stability testing in accordance with ICH\*. The extremely reliable Peltier technology enables operating costs to be reduced by up to 90% compared to compressor technology. Thousands of Memmert Peltier incubators have proven this in utility tests since they have been on the market!



\*International Conference on Harmonisation of Technical Requirements for Registration of Pharmaceuticals for Human Use

## Temperature-humidity working range of Memmert HPP 108

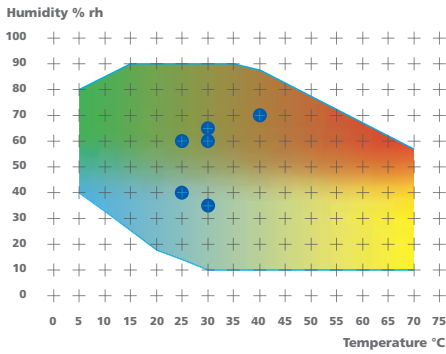

● Temperature and humidity test points defined in the guideline

## Active humidification and dehumidification

In particular, a stable and precisely adjustable relative humidity in the working range of 10-90% is of crucial importance in maintaining a constant climate during stability testing for pharmaceutical products. Your benefits: setpoint temperatures and humidity can be adhered to with precision, even in regions with a high ambient temperature and extremely high or low humidity.

## Dehumidifying, heating and cooling with Peltier

The new HPP is extremely compact, unbelievably quiet and has unsurpassed economic benefits, thanks to its Peltier technology. The advantages of the innovative Memmert Peltier technology at a glance:

- No gases or fluids (coolants) required, and therefore no hazardous waste
- Exceptionally quiet and smooth-running
- Inner chamber hermetically sealed, so there is no exchange of interior air, providing protection from contamination
- Extremely high control precision

## Heating and cooling in a single system

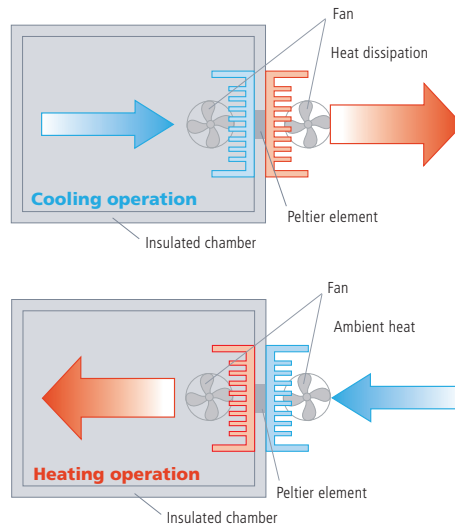

## Energy cost comparison Peltier vs. compressor technology

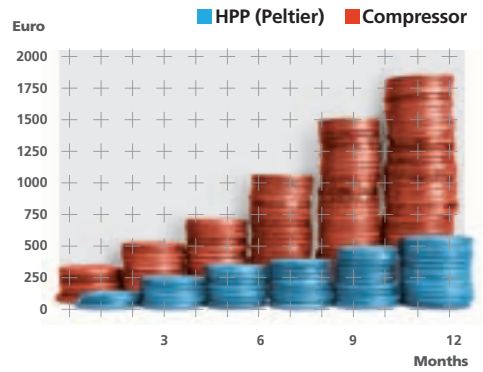

Energy cost comparison HPP (Peltier technology) with conventional unit (compressor cooling) during a stability test acc. to ICH\* (25 °C, 60% rh) – based on competitors' specifications

## Climate protection with a conservation effect

This premium class energy saver reduces strain on the climate, at the same time notably reducing test costs. The main part of ongoing stability testing is performed at temperatures between 20 °C and 30 °C – that is, close to the ambient temperature. The impressive economy of Peltier technology can be seen here, since only small amounts of energy are required to raise or lower the temperature slightly, in comparison with compressor technology.



# Reliable and accurate almost for eternity!



## Long-term comfort

If you are familiar with one Memmert appliance, you will appreciate all of them!

- Clear and easy to clean underglass function display
- Available only from Memmert: the patented push-turn control for intuitive operation of the entire menu
- Fully insulated stainless steel door, as well as inner glass door to observe the chamber load without affecting the temperature
- MEMoryCard XL for programming and logging up to 40 ramps for temperature and humidity
- Quick-release connector for water supply

## Long-term documentation

Through its extensive documentation facilities the HPP conforms to GLP and GMP standards. The basic features for professional quality assurance at a glance:

- Standard software "Celsius" for programming and logging, as well as optionally available (extra charge) FDA-compliant software
- Internal ring memory for seamless long-term documentation that cannot be manipulated (approx. 3 months)
- Parallel printer interface for printouts of thermostating processes (USB printer via converter possible)
- USB interface for programming and storage (Ethernet at extra charge)

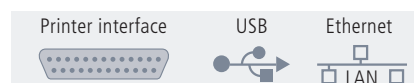

## Long-term stability

Technical refinements for fault-free processes:

- Inner ventilation for homogeneous temperature control conditions
- Multifunctional, fuzzy-supported control
- High-quality and maintenance-free capacitive humidity sensor for high measurement precision
- Calibration facility for temperature and humidity directly on the controller

## Long-term safety

A large amount of details for zero error:

- Integrated self-diagnosis system with optical and acoustic error display
- Multiple temperature monitoring
- Unique Memmert ASF (Automatic Safety Function)
- Two high-grade platinum temperature sensors Pt 100 in a 4-wire circuit with mutual sensor monitoring and function control at equal working temperature
- Acoustic and visible alarm signal in case of temperature and humidity being out of limit, and if water container is empty
- Protection from operation by unauthorised persons: optional, chamber-linked personal User-ID card (extra charge)



### Timer module

- 1 Time indication (here real time)
- 2 Text messages

### Temperature module

- 22 Heating
  - 23 Setpoint/actual temperature
  - 24 Cooling (active)
- Temperature adjustment: +5°C – +70°C
  - Variation (time): ± 0,1 °C max.  
Uniformity (spatial): ± 0,4 °C at 10°C

### Monitor module

- 25 Visual alarm
- 26 Alarm limit
- 27 Sounder on alarm
- 28 LOW alarm limit
- 29 Automatic alarm limit (ASF)
- 30 Temperature limiter
- 31 HIGH alarm limit

Acoustic and visual alarm on temperature and humidity out of limit and on other errors

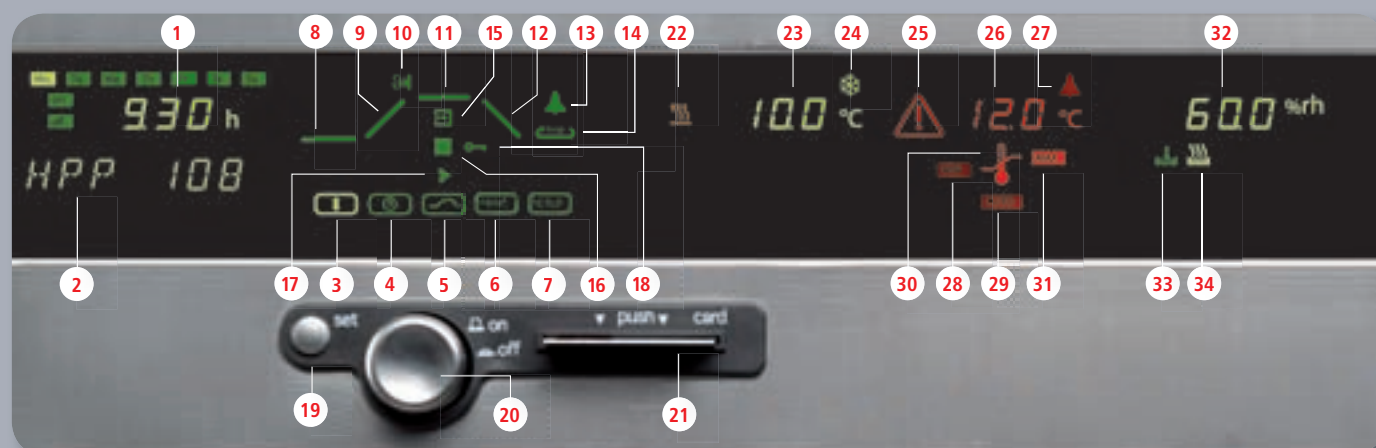

### Operating mode

- 3 Normal operation (active)
  - 4 Weekly timer\*
  - 5 Ramp timer
  - 6 Printer
  - 7 Configuration
  - 8 Wait (at programme start)  
Hold (during programme)
  - 9 Heating ramp
  - 10 Setpoint wait – programme continues when setpoint is reached
  - 11 Hold ramp
  - 12 Cooling ramp
  - 13 Sounder at ramp timer end
  - 14 Repeat function
  - 15 Edit (ramp timer)
  - 16 Stop (ramp timer)
  - 17 Start (ramp timer)
  - 18 Data manipulation prevented through optional User-ID-Card (extra charge)
  - 19 SET key
  - 20 Push/turn control
  - 21 Chip card reader for MEMoryCard and optional User-ID-Card (extra charge)
- \* Weekly timer, programmable with one ON and OFF time per weekday; additional group function (e.g. Mo – Fr)

### Humidity module

- 32 Setpoint/actual humidity
  - 33 Water level in storage tank
  - 34 Steam generation
- Humidity range 10-90% rh
  - Variation (time) ± 1,5% rh max.

## Technical data, models and accessories for constant climate chambers HPP (Humidity Peltier-operated Perfect)

### Interfaces:



optional  
(extra charge): Ethernet LAN



Dimensions of constant climate chambers HPP (see table below)

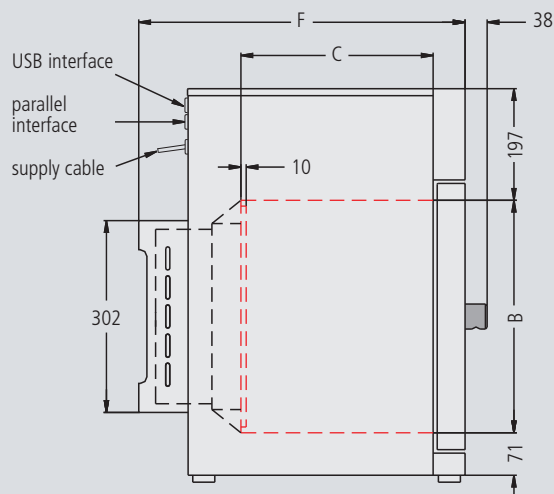
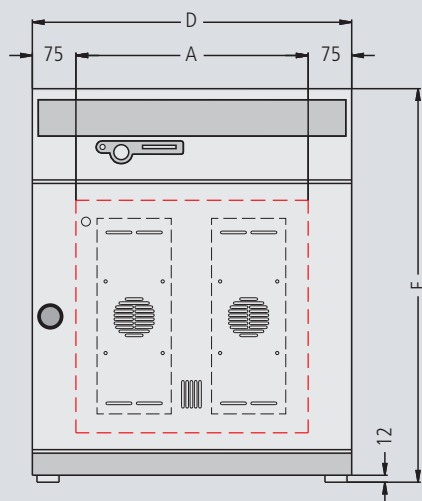

### Model sizes

		HPP	108	749 <b>NEW</b>
Stainless steel interior, mat. 1.4301 (ASTM 304), deep-drawn	Volume	approx. l	108	749
	Width (see sketches above) (A)	mm	560	1040
	Height (see sketches above) (B)	mm	480	1200
	Depth (see sketches above) (C)	mm	400	600
	Provision for sliding stainless steel shelves or wire grid shelves	number	5	14
Stainless steel exterior (rear zinc-plated steel)	Width (D)	mm	710	1190
	Height (E)	mm	760	1620
	Depth (without door handle, depth of handle 38 mm) (F)	mm	620	825
	Extra internal glass door		<input type="checkbox"/>	<input type="checkbox"/>
Temperature	Electronic microprocessor temperature controller with Pt100 and auto-diagnostic system		<input type="checkbox"/>	<input type="checkbox"/>
	Temperature sensors Pt100 Class A in 4-wire circuit for uninterrupted operation on failure of one Pt100 with warning indication		double	double
	Temperature range	°C	from +5 up to +70	from +5 up to +70
	Temperature variation in time (to DIN 12 880: 2007-05)	°C	≤ ± 0,1	≤ ± 0,15
	Temperature uniformity in chamber at 10 °C and 37 °C (to DIN 12 880: 2007-05)	°C	≤ ± 0,4	≤ ± 0,5
Humidity	Capacitive humidity sensor		<input type="checkbox"/>	<input type="checkbox"/>
	Active microprocessor control for humidifying and dehumidifying (10 – 90 % rh), incl. digital indication and auto-diagnostic system ensures even more rapid reaching of set humidity and very short recovery times while avoiding condensate formation; humidity supply with distilled water (from an external tank) by a self-priming pump; integral bacteria block by generating hotsteam		<input type="checkbox"/>	<input type="checkbox"/>
Monitor	Microprocessor temperature monitor acting as overtemperature protection, with Pt100 incorporating fault diagnostics with visual and acoustic alarm		<input type="checkbox"/>	<input type="checkbox"/>
	Digital over- and undertemperature monitor (protection class 3.3)		<input type="checkbox"/>	<input type="checkbox"/>
	Temperature monitoring band automatically linked to the setpoint (ASF)		<input type="checkbox"/>	<input type="checkbox"/>
	Relay for reliable heating cut-off in case of fault		<input type="checkbox"/>	<input type="checkbox"/>
	Acoustic alarm: Over- and undertemperature; over-/underhumidity; empty water tank		<input type="checkbox"/>	<input type="checkbox"/>
Timer functions	Real-time/weekly programmer with group function (e.g. Monday-Friday), programme operation with up to 40 ramps for temperature and humidity (MEMoryCard XL)		<input type="checkbox"/>	<input type="checkbox"/>
Documentation	Internal log memory 1024 kB as ring memory for all setpoints and actual values of temperature and humidity, errors, settings with real-time and date; capacity approx. 3 months at 1 min. intervals		<input type="checkbox"/>	<input type="checkbox"/>
	Parallel printer interface for printing logging files, suitable for all PCL3-compatible ink jet printers (USB available via converter, see accessories)		<input type="checkbox"/>	<input type="checkbox"/>
	„Celsius“ <sup>1)</sup> software for control and documentation of temperature and relative humidity		<input type="checkbox"/>	<input type="checkbox"/>
Setup	Calibration (no separate PC required), <u>temperature</u> : 3-point calibration on controller, <u>humidity</u> : 2-point calibration at 20% and 90%		<input type="checkbox"/>	<input type="checkbox"/>
	Setting of language for dialogue and display D / UK / E / F / I		<input type="checkbox"/>	<input type="checkbox"/>

Model sizes		HPP	108	749 <b>NEW</b>
Further data	Electrical load (during heating and cooling)	approx. W	350	1050
	Electrical supply 230 V <sup>2)</sup> (± 10%), 50/60 Hz	V	230	230
	Net weight	approx. kg	66	218
	Gross weight	approx. kg	70	278
Standard accessories	Stainless steel sliding shelves (HPP 108), stainless steel grids (HPP 749)	number	2 <input type="checkbox"/>	2 <input type="checkbox"/>
	Shelf or wire grid shelf width (grids to order; extra charge)	approx. mm	556	1036
	Shelf or wire grid shelf depth	approx. mm	361	530
	Works calibration certificate at 10 °C and 37 °C at 60% rh (test point chamber centre)		<input type="checkbox"/>	<input type="checkbox"/>
Standard version	Constant climate chamber HPP		<b>HPP 108</b>	<b>HPP 749</b>
Options	Locking door (security lock)		B6	B6
	Extra stainless steel shelf		E0(x)	E0(x)
	Extra stainless steel tray (non-perforated) 15 mm rim (may affect the temperature distribution)		E2(x)	E2(x)
	Stainless steel grid (for good air circulation)		E3(x)	E3(x)
	Moisture-tight entry port for introducing connections <u>at the side</u> , can be closed from inside by silicone stopper, (standard position centre/centre or centre top, 23 mm clear diameter)	left centre/centre left centre top right centre/centre right centre top	F0 F1 F2 F3	F0 F1 F2 F3
	Stacking version for 2 units of equal size (bottom unit modification)		G3	–
	Temperature profile write/read unit for programming via PC, for writing to and reading from the chip card, up to 40 ramps		V3	V3
	Additional chip card, blank, formatted (32 kB MEMoryCard XL for a maximum of 40 ramps)		V4	V4
	Oven-linked authorisation card (User-ID-Card) prevents undesired manipulation by unauthorised third parties		V1	V1
	Computer interface RS485 (for networking a maximum of 16 ovens) instead of USB interface		V2	V2
	RS232 interface instead of USB		W6	W6
	Interface Ethernet instead of USB inclusive software "Celsius Ethernet-Edition"		W4	W4
	Parallel/USB converter cable with integrated power supply unit to connect PCL-3 compatible HP printers with USB interface to MEMMERT units		W1	W1
	Documentation package consisting of parallel USB converter cable including PLC3- compatible HP colour inkjet printer with USB interface (HP Deskjet 6940 or successor) for direct connection of printer to Memmert unit		W2	W2
	USB connection cable for computer interface		W7	W7
	Flexible Pt100 for positioning in chamber or in load with socket, 4-pin, according to NAMUR NE 28, for external temperature recording (load temperature)		H4	H4
	Potential-free contact (24 V/2 A) with socket, according to NAMUR NE 28 for external monitoring (indicates when setpoint is reached)		H5	H5
	ditto, according to NAMUR NE 28 for combination error message (e.g. supply failure, sensor fault, fuse)		H6	H6
	ditto, triple, for signal generation, controlled by programme segment (using PC) for a total of 3 freely selected functions to be activated (e.g. acoustic and visual signals, exhaust motors, fans, stirrers etc.)		H7	H7
	Additional Pt100 temperature sensor, positioned flexibly in chamber or load, for local temperature measurement (up to 3 additional sensors are possible). The measured temperature can, if required, be indicated on the multifunction display, recorded in the integral ring store, and can be documented via the „Celsius“ <sup>1)</sup> software or on an attached printer		H8(x)	H8(x)
	Works calibration certificate for one temperature and humidity according to customer specification		Z4	Z4
	IQ check list with works test data for chamber as support for validation by customer		Q1	Q1
	OQ-check list with works test data for one freely selectable humidity and temperature value <sup>3)</sup> incl. temperature distribution survey for 27 measuring points to DIN 12880-2007:05 as support for validation by customer		Q2	Q2
Software „Celsius FDA Edition“ <sup>4)</sup> - meets the requirements for the use of electronically stored data sets and electronic signatures as laid down in Regulation 21 CFR Part 11 of the US Food and Drug Administration (FDA) <ul style="list-style-type: none"> <li>• storage of setpoint profiles and documentation data protected against manipulation</li> <li>• user identification with password protection</li> <li>• control of access authorisation of individual users through the administrator</li> <li>• traceability through protected audit trail file</li> <li>• protection against and registration of unauthorised access and manipulation attempts</li> <li>• unique assignment of documentation data through linkage with serial number</li> <li>• use of optional User-ID-Card is recorded in the documentation data</li> </ul>		Q3	Q3	
Integration of additional units (up to max. 16 units) into an already existent FDA-software licence		Q4	Q4	

Subject to technical modifications

1) MEMMERT "Celsius" software has been tested for Windows NT 4, 2000, XP and Vista  
2) Option 115 V, 50/60 Hz for HPP 108 free-of-charge, for HPP 749 at extra cost

3) Additional temperature and humidity values at extra cost for each additional value  
4) Requires Windows 2000 Professional or XP Professional

Standard model, basic specification  
– Not available  
(x) Please specify quantity required after the order number

# OUR PROGRAMME

Universal ovens  
Incubators  
Hot air sterilisers

## Ovens



## Vacuum ovens



Peltier-cooled incubators  
Compressor-cooled incubators

## Cooled incubators



## CO<sub>2</sub> incubators



## Humidity chambers



## Constant climate chambers



## Climatic test chambers



## Water- and oilbaths



Your Memmert Partner

Upon your request we are pleased to send you detailed brochures



### Memmert GmbH + Co. KG

P.O. Box 1720  
D-91107 Schwabach  
Germany  
Tel. +49 (0) 9122 / 925 - 0  
Fax +49 (0) 9122 / 145 85  
E-Mail: sales@memmert.com

[www.memmert.com](http://www.memmert.com)

Some of the illustrations in this publication include special accessories. We reserve the right of technical modifications. Dimensions are subject to confirmation.